

ENGINEERING DRAWING

(NSQF)

(As per Revised Syllabus July 2022)

Group 10

Plastic Processing Operator



Directorate General of Training

DIRECTORATE GENERAL OF TRAINING
MINISTRY OF SKILL DEVELOPMENT & ENTREPRENEURSHIP
GOVERNMENT OF INDIA



**NATIONAL INSTRUCTIONAL
MEDIA INSTITUTE, CHENNAI**

Post Box No. 3142, CTI Campus, Guindy, Chennai - 600 032

Engineering Drawing (NSQF) 1 Year
Group 10 Engineering Trades
As per Revised syllabus July 2022 under CTS

Developed & Published by



National Instructional Media Institute

Post Box No.3142
Guindy, Chennai - 600032
INDIA
Email: chennai-nimi@nic.in
Website: www.nimi.gov.in

Copyright © 2023 National Instructional Media Institute, Chennai

First Edition : December 2023

Copies : 1000

Rs.120/-

All rights reserved.

No part of this publication can be reproduced or transmitted in any form or by any means, electronic or mechanical, including photocopy, recording or any information storage and retrieval system, without permission in writing from the National Instructional Media Institute, Chennai.

FOREWORD

The Government of India has set an ambitious target of imparting skills one out of every four Indians, to help them secure jobs as part of the National Skills Development Policy. Industrial Training Institutes (ITIs) play a vital role in this process especially in terms of providing skilled manpower. Keeping this in mind, and for providing the current industry relevant skill training to Trainees, ITI syllabus has been recently updated with the help of comprising various stakeholder's viz. Industries, Entrepreneurs, Academicians and representatives from ITIs.

The National Instructional Media Institute (NIMI), Chennai, has now come up with instructional material to suit the revised curriculum for **Engineering Drawing NSQF Group 10 Engineering Trades (Revised 2022)** under CTS will help the trainees to get an international equivalency standard where their skill proficiency and competency will be duly recognized across the globe and this will also increase the scope of recognition of prior learning. NSQF trainees will also get the opportunities to promote life long learning and skill development. I have no doubt that with NSQF the trainers and trainees of ITIs, and all stakeholders will derive maximum benefits from these IMPs and that NIMI's effort will go a long way in improving the quality of Vocational training in the country.

The Director General, Executive Director & Staff of NIMI and members of Media Development Committee deserve appreciation for their contribution in bringing out this publication.

Jai Hind

ATUL KUMAR TIWARI, I.A.S

Secretary

Ministry of Skill Development & Entrepreneurship,
Government of India.

December 2023

New Delhi - 110 001

PREFACE

The National Instructional Media Institute(NIMI) was set up at Chennai, by the Directorate General of Training, Ministry of skill Development and Entrepreneurship, Government of India, with the technical assistance from the Govt of the Federal Republic of Germany with the prime objective of developing and disseminating instructional Material for various trades as per prescribed syllabus and Craftsman Training Programme(CTS) under NSQF levels.

The Instructional materials are developed and produced in the form of Instructional Media Packages (IMPs), consisting of Trade Theory, Trade Practical, Test and Assignment Book, Instructor Guide, Wall charts. The above material will enable to achieve overall improvement in the standard of training in ITIs.

A national multi-skill programme called SKILL INDIA, was launched by the Government of India, through a Gazette Notification from the Ministry of Finance (Dept of Economic Affairs), Govt of India, dated 27th December 2013, with a view to create opportunities, space and scope for the development of talents of Indian Youth, and to develop those sectors under Skill Development.

The emphasis is to skill the Youth in such a manner to enable them to get employment and also improve Entrepreneurship by providing training, support and guidance for all occupation that were of traditional types. The training programme would be in the lines of International level, so that youths of our Country can get employed within the Country or Overseas employment. The **National Skill Qualification Framework (NSQF)**, anchored at the National Skill Development Agency(NSDA), is a Nationally Integrated Education and competency-based framework, to organize all qualifications according to a series of **levels of Knowledge, Skill and Aptitude**. Under NSQF the learner can acquire the Certification for Competency needed at any level through formal, non-formal or informal learning.

The **Engineering Drawing** NSQF Group 10 - Engineering Trades (Revised 2022) under CTS is one of the book developed by the core group members as per the NSQF syllabus.

The **Engineering Drawing** NSQF Group 10 - Engineering Trades under (Revised 2022) CTS as per NSQF is the outcome of the collective efforts of experts from Field Institutes of DGT, Champion ITI's for each of the Sectors, and also Media Development Committee (**MDC**) members and Staff of **NIMI**. NIMI wishes that the above material will fulfill to satisfy the long needs of the trainees and instructors and shall help the trainees for their Employability in Vocational Training.

NIMI would like to take this opportunity to convey sincere thanks to all the Members and Media Development Committee (MDC) members.

Chennai - 600 032

EXECUTIVE DIRECTOR

ACKNOWLEDGEMENT

The National Instructional Media Institute (NIMI) sincerely acknowledge with thanks the co-operation and contribution of the following Media Developers to bring this IMP for the course **Engineering Drawing Group 10 - Engineering Trades** as per NSQF Revised 2022.

MEDIA DEVELOPMENT COMMITTEE MEMBERS

Shri. M. Sangara pandian	-	Training Officer (Retd.) CTI, Govt. of India, Guindy, Chennai - 32.
Shri. G. Sathiamoorthy	-	Jr. Training Officer - SG (Retd.) Govt I.T.I, Trichy, DET - Tamilnadu.
Shri. R. Sekaran	-	Jr. Training Officer (Retd.), Govt I.T.I, Ambattur, Chennai - 600098.

NIMI CO-ORDINATORS

Shri. Nirmalya Nath	-	Deputy General Manager, NIMI, Chennai - 32.
Shri. G. Michael Johny	-	Manager, NIMI, Chennai - 32.

NIMI records its appreciation of the **Data Entry, CAD, DTP Operators** for their excellent and devoted services in the process of development of this IMP.

NIMI also acknowledges with thanks, the efforts rendered by all other staff who have contributed for the development of this book.

INTRODUCTION

Theory and procedure along with the related exercises for further practice

This book on theory and procedure along with related exercises contains theoretical information on **1 Year Engineering drawing** NSQF (Revised syllabus July 2022 Group 10 - Engineering Trades) and procedure of drawing/ sketching different exercise for further practice are also available. Wherever required, BIS specification has been used.

Exercise for further practice

The practice exercise is given with Theory and procedure for 1 Year book made obsolete as it was felt that, it is very difficult to work in workbook using drawing instruments. It is well known fact that, any drawing is prepared on suitable standard size of drawing sheets only.

The instructor is herewith advised to go through the instructions given below and to follow them in view of imparting much drawing skill in the trainees.

Acquiring the above said ability and doing small drawings is not a simple task. These books will provide a good platform for achieving the said skills.

Time allotment - 1 Year : 40 Hrs

Sl. No.	Topic	Exercise No.	Time Allotment
1	Introduction to Engineering Drawing and Drawing Instruments	1.1.01 - 1.1.05	2
2	Lines and Free hand drawing	1.2.06 - 1.2.09	6
3	Drawing of Geometrical Figures	1.3.10 - 1.3.13	4
4	Dimensioning	1.4.14 - 1.4.16	2
5	Symbolic Representation	1.5.17	4
6	Concept and Reading of Drawing	1.6.18 - 1.6.20	14
7	Reading of Job drawing of related trades	1.7.21	8
			<hr/> 40 Hrs

Instructions to the Instructors

It is suggested to get the drawing prepared on A4/A3 sheets preferably on only one side. If separate table and chair facility is available for every trainee then it is preferred to use A3 sheets and if the drawing hall is provided with desks then A4 sheets may be used. However while preparing bigger drawings on A4 sheets suitable reduction scale to be used or multiple sheets may be used for detailed and assembly drawings.

First the border and the title block to be drawn only for the first sheet of the chapter. Eg. for conical sections only first sheet will have the title block whereas the rest of the sheets of that chapter will have only borders.

Serial number of sheet and total no. of sheets to be mentioned on each sheet.

The completed sheet to be punched and filled in a box file/ suitable files and preserved by the trainees carefully after the approval of instructor, VP and Principal of the Institute.

The file may be referred by the authority before granting the internal marks at the end of the Year.

CONTENTS

Exercise No.	Topic of the Exercise	Page No.
	Introduction to Engineering Drawing and Drawing Instruments	
1.1.01	Introduction to engineering drawing and drawing instruments	1
1.1.02	Conventions	4
1.1.03	Sizes and layout of drawing sheets	5
1.1.04	Title block, its position and content	7
1.1.05	Drawing instruments	11
	Lines and Free hand drawing	
1.2.06	Lines - Types and applications in drawing	16
1.2.07	Free hand drawing of - Geometrical figures and blocks with dimension	22
1.2.08	Free hand drawing of - Transferring measurement from the given object to the free hand sketches	25
1.2.09	Free hand drawing of hand tools and measuring tools	29
	Drawing of Geometrical Figures	
1.3.10	Drawing of geometrical figures - Angle & triangle	31
1.3.11	Drawing of geometrical figures - Circle	34
1.3.12	Drawing of geometrical figures - Square, rectangle and parallelogram	36
1.3.13	Lettering and numbering - Single stroke	38
	Dimensioning	
1.4.14	Dimensioning - Types of arrow heads and leader line with text	42
1.4.15	Dimensioning - Position of dimensioning (aligned, unidirectional)	43
1.4.16	Practice of dimensioning	48
	Symbolic Representation	
1.5.17	Different symbols used in the plastic processing operator trade	51
	Concept and Reading of Drawing	
1.6.18	Concept and reading of drawing in - Concept of axes plane and quadrant	57
1.6.19	Concept and reading of drawing in - Concept of orthographic projection and isometric projections	60
1.6.20	Method of 1 st angle and 3 rd angle projections (definition and difference)	68
	Reading of Job drawing of related trades	
1.7.21	Reading of Job drawing related to plastic processing operator trade	71

LEARNING / ASSESSABLE OUTCOME

On completion of this book you shall be able to

- **Read and apply engineering drawing for different application in the field of work.**

SYLLABUS

1 Year

Group 10 - Revised syllabus July 2022
Engineering trades under CTS

Duration: 1 Year

CTS Trades Covered: Plastic Processing Operator

S.no.	Syllabus	Time in Hrs
1	Introduction to Engineering Drawing and Drawing Instruments – <ul style="list-style-type: none">• Conventions• Sizes and layout of drawing sheets• Title Block, its position and content• Drawing Instruments	2
2	Lines - Types and applications in drawing Free hand drawing of - <ul style="list-style-type: none">• Geometrical figures and blocks with dimension• Transferring measurement from the given object to the free hand sketches.• Free hand drawing of hand tools and measuring tools.	6
3	Drawing of Geometrical figures: <ul style="list-style-type: none">• Angle, Triangle, Circle, Rectangle, Square, Parallelogram.• Lettering & Numbering - Single Stroke.	4
4	Dimensioning <ul style="list-style-type: none">• Types of arrowhead• Leader line with text• Position of dimensioning (Unidirectional, Aligned)	2
5	Symbolic representation - <ul style="list-style-type: none">• Different symbols used in the Plastic Processing Operator trade	4
6	Concept and reading of Drawing in <ul style="list-style-type: none">• Concept of axes plane and quadrant• Concept of Orthographic and Isometric projections• Method of first angle and third angle projections (definition and difference)	14
7	Reading of Job drawing related to Plastic Processing Operator trade	8
	Total	40

Introduction to engineering drawing and drawing instruments

Communication

There are many different ways of communicating ideas, information, instructions, requests, etc. They can be transmitted by signs or gestures, by word of mouth, in writing, or graphically. In an industrial context the graphical method is commonly used with communication is achieved by means of engineering drawings.

If oral and written communication only were used when dealing with technical matters, misunderstandings could arise, particularly in relation to shape and size. The lack of a universal spoken language makes communication and understanding even more difficult because of the necessity to translate both words and meaning from one language to another.

However, the universally accepted methods used in graphical communication through engineering drawings eliminate many of these difficulties and make it possible for drawing prepared by a British designer to be correctly interpreted or "read" by, for example, his German, French or Dutch counterparts.

Equally important, the components shown on the drawings could be made by suitably skilled craftsmen of any nationality provided they can "read" an engineering drawing.

Conventionally prepared engineering drawings provide the main means of communication between the "ideas" men (the designers and draughtsman) and the craftsmen (machinists, fitters, assemblers, etc.). For the communication to be effective, everyone concerned must interpret the drawing in the same way. Only then will the finished product be exactly as the designer envisages it.

To ensure uniformity of interpretation, the British Standards Institution has prepared a booklet entitled BS 308:1972, Engineering Drawing Practice. Now in three parts, this publication recommends the methods which should be adopted for the preparation of drawing used in the engineering industry.

The standards and conventions in most common use and hence those required for a basic understanding of engineering drawing are illustrated and explained in this book.

Language

1 It is the media of communication (Fig 1)

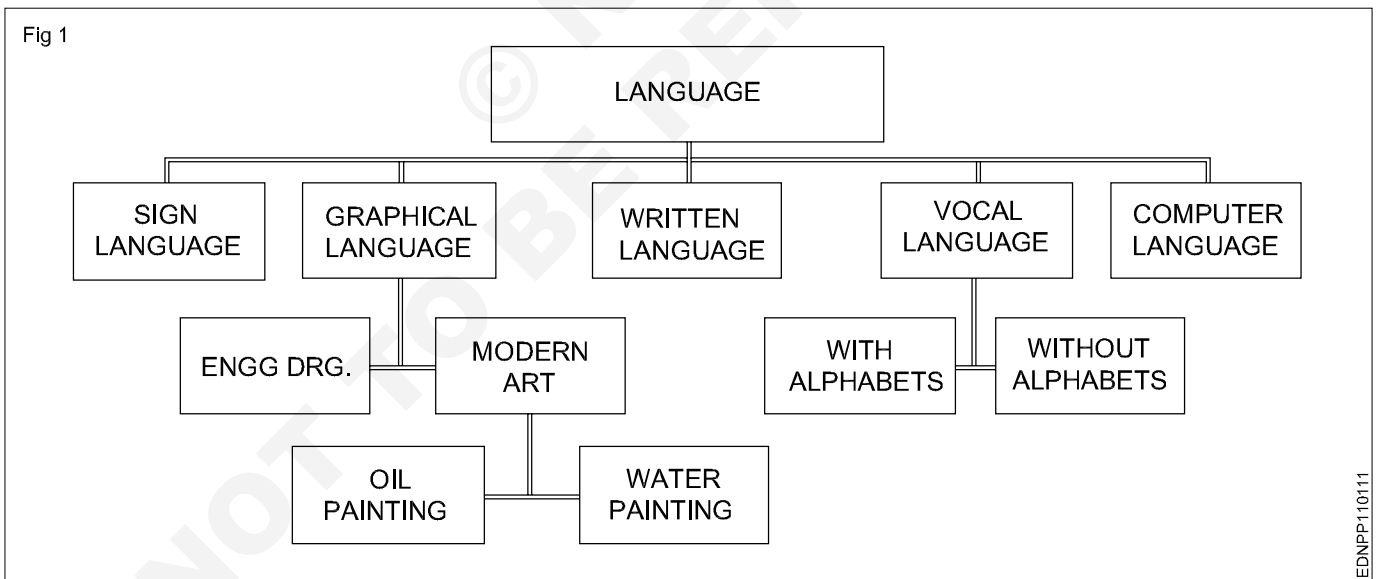

EDNPP110111

Conclusion

Effective communication is possible when graphical language is supported by written language/vocal language and vice versa.

Engineering drawing is a language that uses both graphical language and written language for effective communication.

Engineering drawing is a graphical language that also uses written language for effective communication.

The importance of Engineering Drawing

The economic success of any country is mainly dependent on its industrial development. Due to globalization, any industry in our country is expected to be of a global market standard. For the above-mentioned reasons, our Indian products require very high quality for their size, dimension, fit, tolerance, and finish etc.

To produce the best standard product, all the technical personnel (Engineers to Craftsman) in an industry must have a sound knowledge of engineering drawing because engineering drawing is the language of engineers. Engineering drawing is a universal language. Different types of lines make up their alphabets. Technical personnel in any industry, including craftsman, are expected to communicate anything concerning a part or a component by means of drawings involving lines, symbols, conventions, abbreviations etc.

With our spoken languages, it is impossible to express the details of a job or a product. Engineering drawing knowledge and practise are a must for designing or producing a component or part. Even a small mistake in the drawing may reflect very badly on the product. Therefore, reading and doing engineering drawings are very essential for craftsmen and engineers.

A drawing is a graphical representation of an object, or part of it, and is the result of creative thought by an engineer or technician. When one person sketches a rough map in giving direction to another, this is graphic communication. Graphic communication involves using visual materials to relate ideas. Drawings, photographs, slides, transparencies, and sketches are all forms of graphic communication. Any medium that uses a graphic image to aid in conveying a message, instructions, or an idea is involved in graphic communication.

One of the most widely used forms of graphic communication is the drawing. Technically, it can be defined as **"a graphic representation of an idea, a concept or an entity which actually or potentially exists in life"**

Drawing is one of the oldest forms of communicating, dating back even farther than verbal communication. The drawing itself is a method of communicating necessary information about an abstract, such as an idea or concept or a graphic representation of some real entity, such as a machine part, house or tools. There are two basic types of drawings: Artistic and Technical drawings.

Technical drawings

Technical drawings allows efficient communication among engineers and can be kept as a record of the planning process. Since a picture is worth a thousand words, a technical drawing is a much more effective tool for engineers than a written plan.

The technical drawing, on the other hand is not subtle, or abstract. It does not require an understanding of its creator, only on understanding of technical drawings. A technical drawing is a means of clearly and concisely communicating all of the information necessary to transform an idea or a concept in to reality. Therefore, a technical drawing often contains more than just a graphic representation of its subject. It also contains dimensions, notes and specifications.

Fields of use

Technical drawing is the preferred method of drafting in all engineering fields, including, but not limited to, civil engineering, electrical engineering, mechanical engineering and architecture.

Purpose of studying engineering drawing

- 1 To develop the ability to produce simple engineering drawing and sketches based on current practice
- 2 To develop the skills to read manufacturing and construction drawings used in industry.
- 3 To develop a working knowledge of the layout of plant and equipment.
- 4 To develop skills in abstracting information from calculation sheets and schematic diagrams to produce working drawings for manufacturers, installers and fabricators.

Main types of Engineering drawing

Regardless of branch of engineering the engineering drawing is used. However based on the major engineering branches, engineering drawing can be classified as follows: (Fig 2)

Mechanical Engineering drawings

Some examples of mechanical engineering drawings are part and assembly drawings, riveted joints, welded joints, fabrication drawings, pneumatics and hydraulics drawings, pipeline diagrams, keys coupling drawings etc. (Fig 3&4)

Electrical engineering drawing

Wiring diagrams of home and industries, circuit diagrams, electrical installation drawings etc.

Example

The voltage supply to a filament lamp is 10.8V. The voltage should be 12V. (Fig 5)

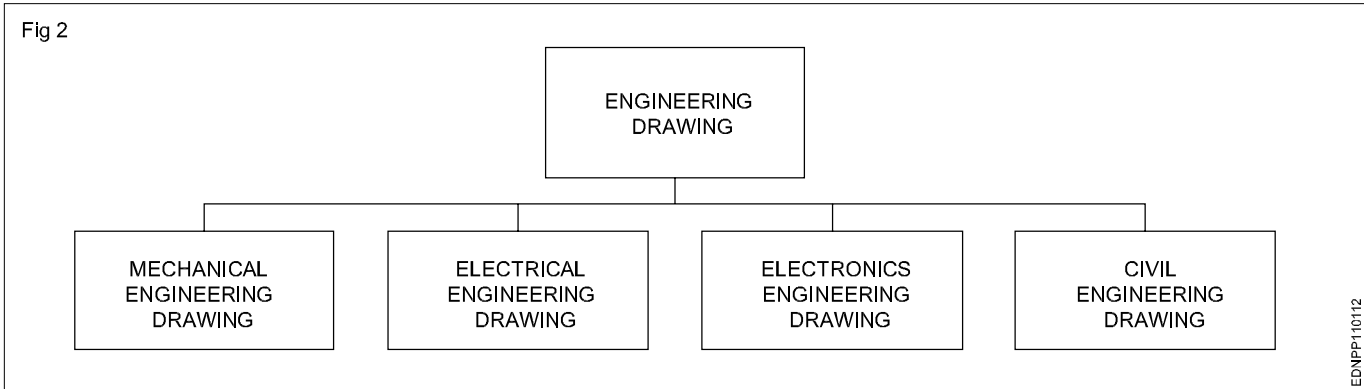

Mechanical Engineering Drawings (Fig 3&4)

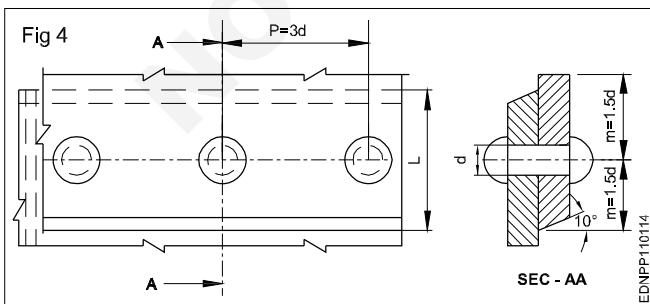
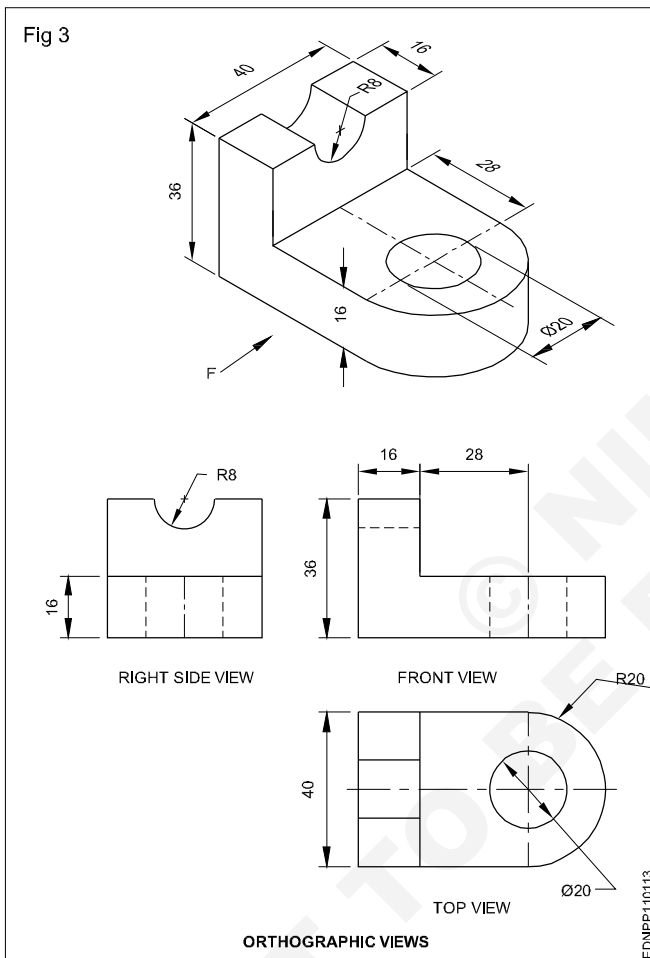

Electrical Engineering Drawing (Fig 5)

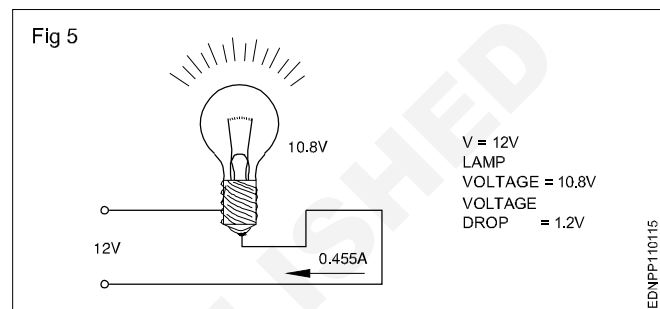

Electronics Engineering Drawing

Audio amplifier (Fig 6)

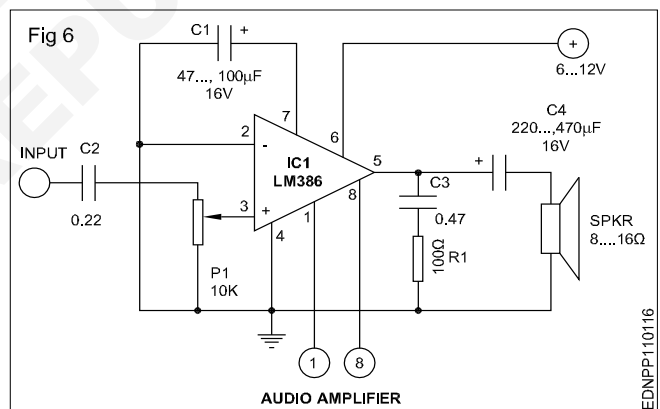

Civil Engineering Drawing (Fig 7)

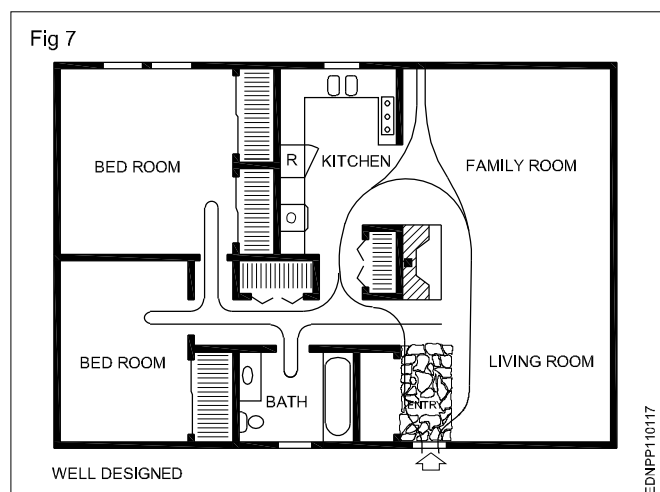

Conventions

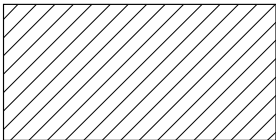
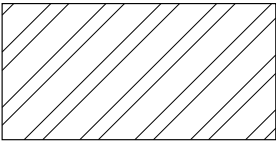
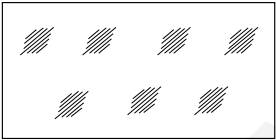
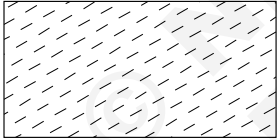
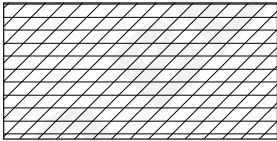
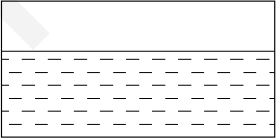
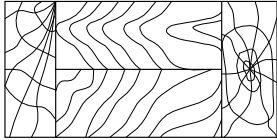
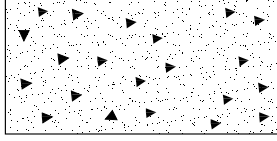
TYPE	CONVENTION	MATERIALS
Metals		Steel, Cast Iron, Copper and its Alloys, Aluminium and its alloy, etc
		Lead, Zinc, Tin, White-metal, etc.
Glass		Glass
Packing and Insulating materials		Porcelain, Stoneware, Marble, Slate etc
		Asbestos, Fibre, Felt, Synthetic resin products, Paper, Cork, Linoleum, Rubber, Leather, Wax, insulating & Filling Materials etc
Liquid		Water, Oil, Petrol, Kerosene etc
Wood		Wood, Plywood etc
Concrete		Concrete

Sizes and layout of drawing sheets

Size of drawing sheets (in mm): While being worked on or handled, the drawing sheets are prone to tear along the edges. So slightly larger(untrimmed) sheets are preferred. They are trimmed afterwards. IS:10811:1983 lays down such as designation of preferred trimmed and untrimmed sizes.

Designation of sheets: The drawing sheets are designated by symbols such as A0, A1, A2, A3, A4 and A5. A0 being the largest and A5 is smallest. Table 1 below gives the length and breadth of the above sizes of sheets. (Trimmed and untrimmed)

The relationship between two sides in same as that between a side of a square and its diagonal.

TABLE 1

Designation	Trimmed size	Untrimmed size
A0	841 x 1189	880 x 1230
A1	594 x 841	625 x 880
A2	420 x 594	450 x 625
A3	297 x 420	330 x 450
A4	210 x 297	240 x 330
A5	148 x 210	165 x 240

Special elongated series increasing its widths, double, treble etc. are denoted as follows A3 x 3, A3 x 4, A4 x 3, A4 x 4, A4 x 5. Please refer Table 2.

TABLE 2

Special elongated series

Designation	Size
A3 x 3	420 x 891
A3 x 4	420 x 1189
A4 x 3	297 x 630
A4 x 4	297 x 841
A4 x 5	297 x 1051

Fig 1 & 2 shows how the sheet sizes are formed by halving/doubling and similarity of format.

White drawing papers that do not turn yellow on exposure to air are used for finished drawings, maps, charts and drawings for photographic reproductions.

For pencil layouts and working drawings, cream-coloured papers are best suited.

Quality drawing paper: The drawing papers should have sufficient teeth or grain to take the pencil lines and withstand repeated erasing.

To get uniform lines, backing paper is to be placed on the drawing board before fixing drawing/tracing paper. Before starting the drawing, the layout should be drawn. (Ref: IS:10711)

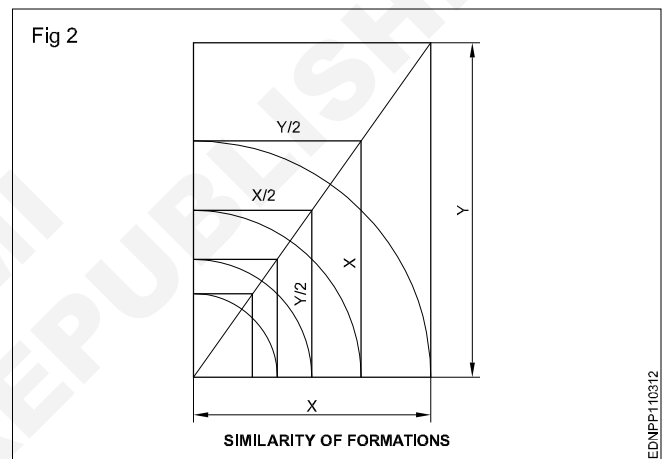
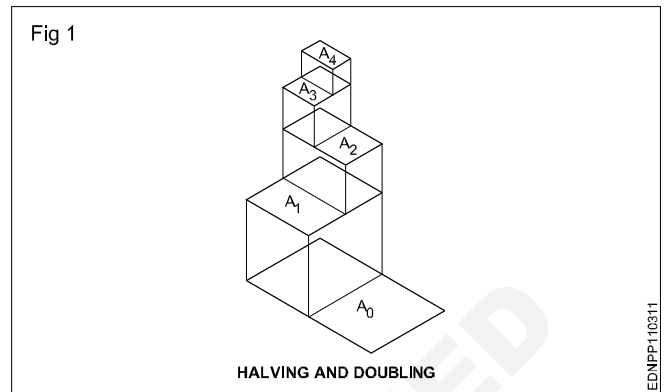

The following is the method of folding printed drawing sheets as recommended by BIS. (Fig 3)

Method of folding of printed drawing sheets as per BIS SP: 46-2003

When drawings sheets are in more numbers, they have to be folded and kept in order to save the trace required for preserving them (Fig 4).

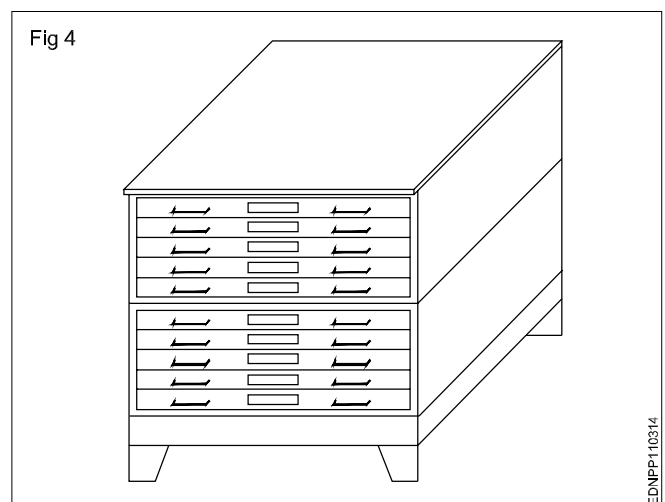

EDNPP110311

EDNPP110312

EDNPP110314

Method of folding printed drawing sheets (Fig 3)

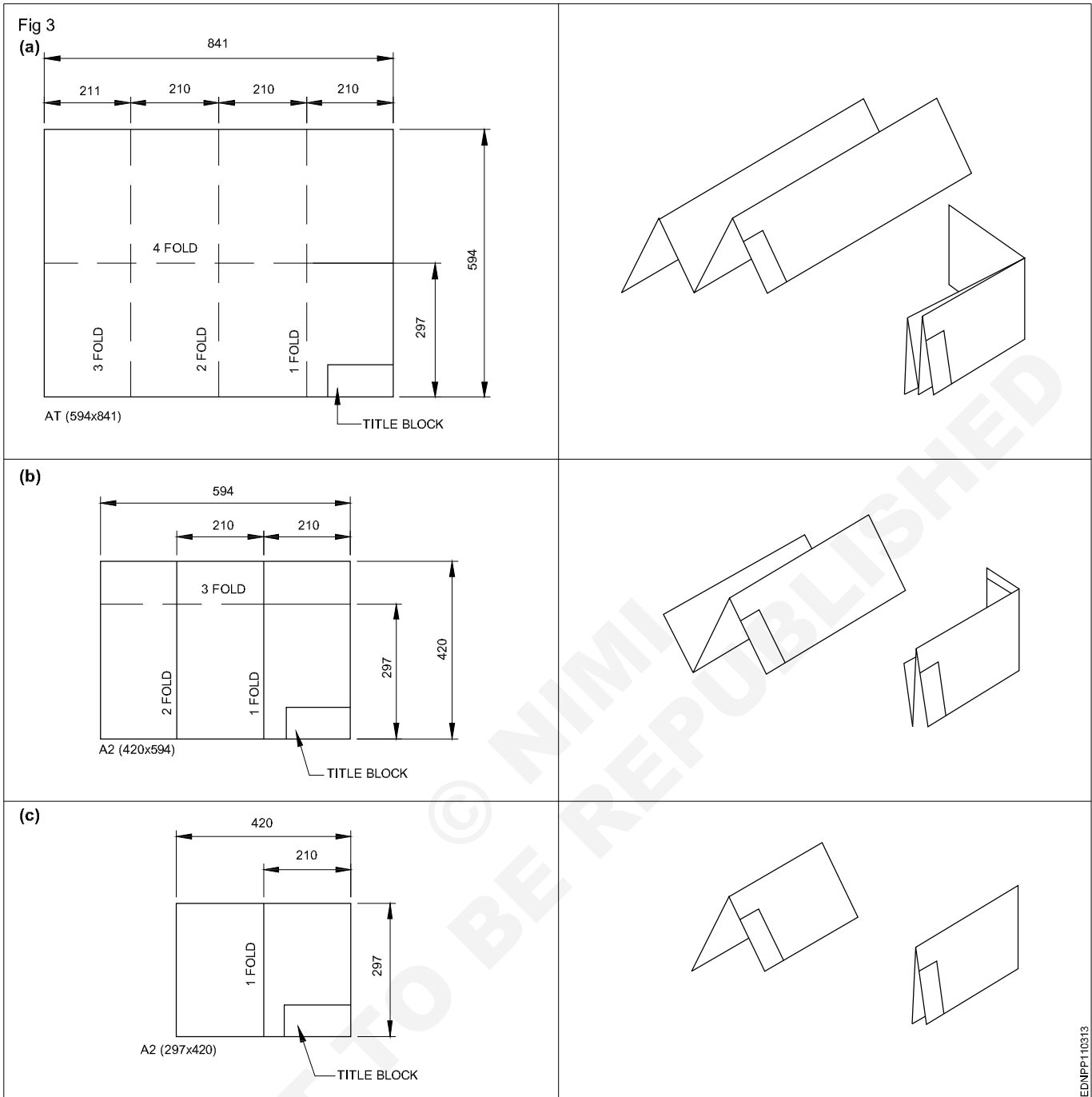

EDNPF110313

Title block, its position and content

Layout of drawing sheet

As a standard practice, sufficient margins are to be provided on all sides of the drawing sheet. The drawing sheet should have drawing space and title space. A typical layout of a drawing sheet is shown in the (Fig 1 & 2).

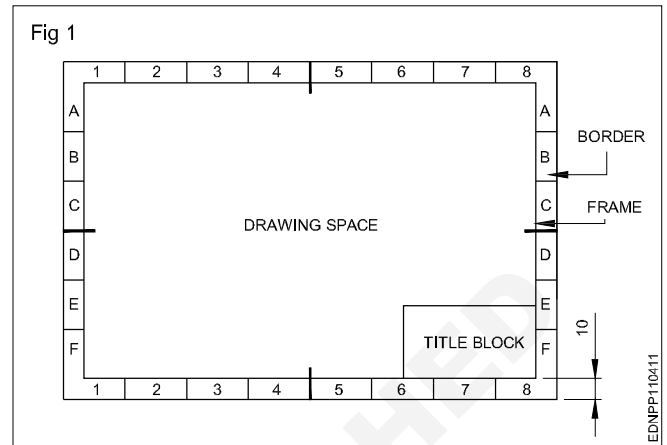

Title Block - 1

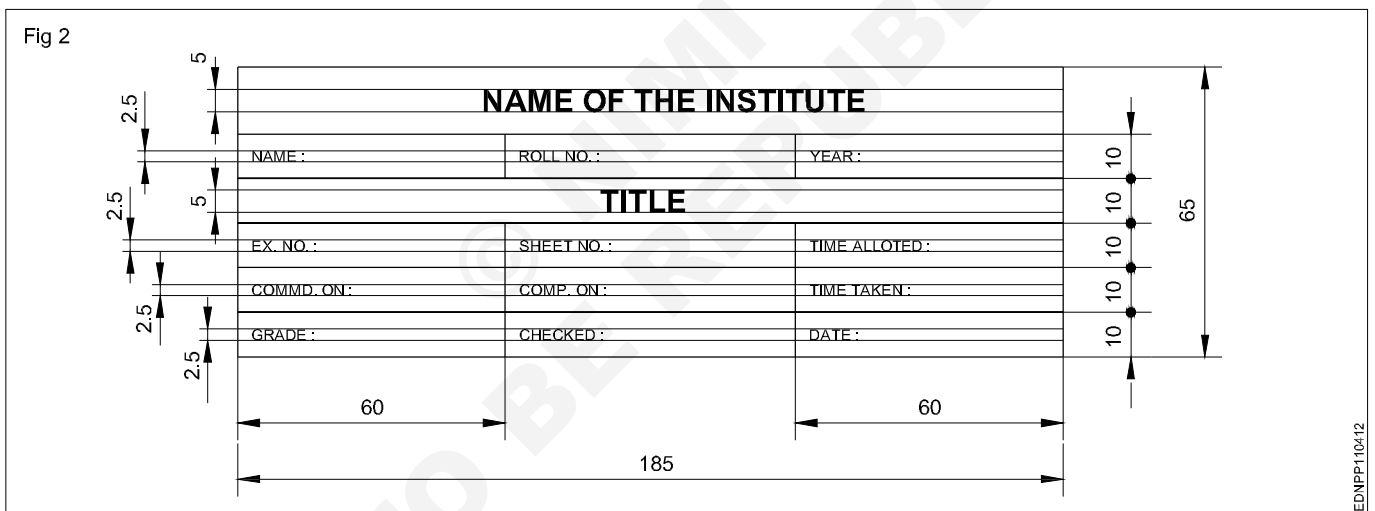

Title Block - 2

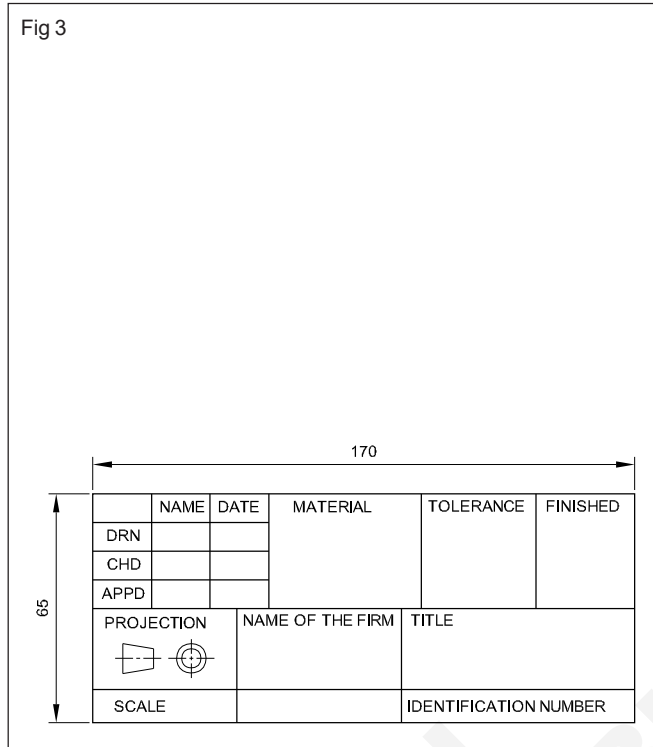

Title Block - 3

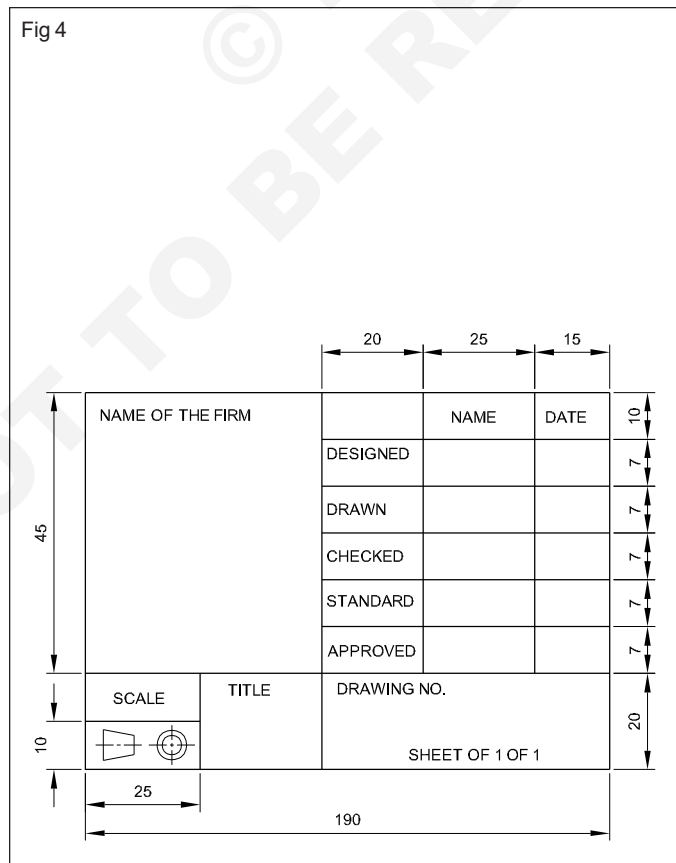

Title Block - Position and content - 1

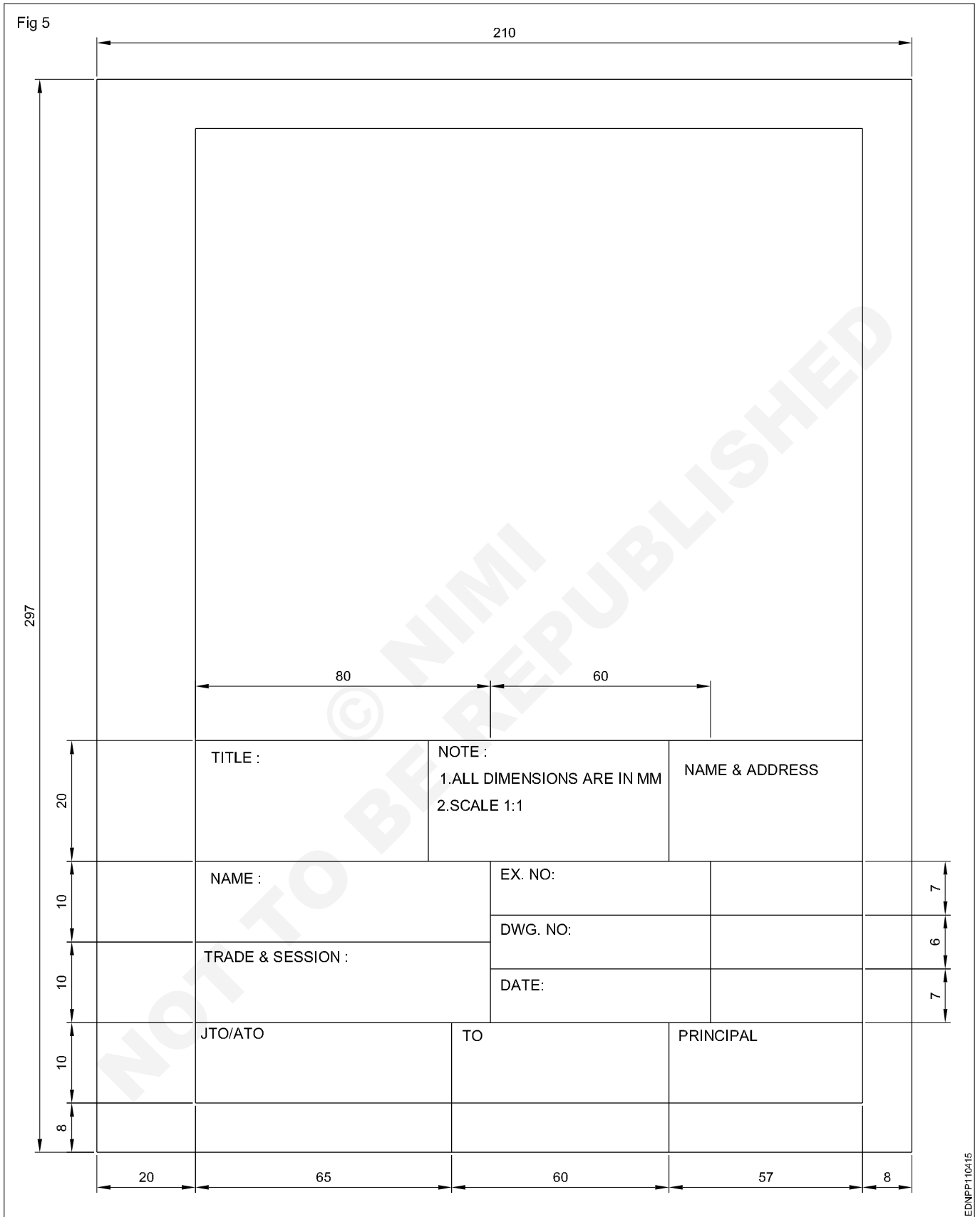

Title Block - Position and content - 2

Fig 6

DO NOT SCALE

REVISION			
SL.N	DESCRIPTION	DATE	APPX
A	M12 WAS ½ WHIT.	14.12.18	A.W.D

4			
3			
2			
1	A7325	VALVE BODY	1
DRG OR PART NO.	DESCRIPTION	QTY.	

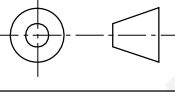
UNLES OTHERWISE STATED ALL DIMENSIONS IN MILLIMETRES. TOLERANCES LINEAR: ANGULAR:		DRN 1:1:78 JKL	(NAME OD THE FIRM)
	MATERIAL : CAST STEEL	CKD 2:1:78 MLN	
DRAFTING STANDARD AS 1100	FINISH AS MACHINED	APPD 5:1:78 AWB	(TITLE OF DRW.)
		ISSUED 4:2:78 PFP	SIZE A3
		SCALE 1:2	DRG NO A24641
			SHEET 1 OF 1

EDNPP110416

Item Reference on Drawing Sheet

05	TIGHTENING PIN	01	MILD STEEL	
04	WORK PIECE	01	ANY MATL.	
03	SCREW ROD	01	STD.	
02	"U" CLAMP	01	CAST IRON	
01	"V" BLOCK	01	CAST IRON	
PART NO	DESCRIPTION OF ITEM	QTY/ASSY	MATERIAL	REMARKS
BILL OF MATERIALS				

The drawing sheet on which the drawings to be prepared should be prepared first by following the procedure given below:

- 1 Take A4/A3 drawing sheet.
- 2 Mark the borders and draw the title block as mentioned.
- 3 Follow the same procedure for A3 drawing sheet where the title block is to be drawn right side bottom corner and the border dimensions remain same.
- 4 Title block to be drawn whenever the title of the drawing changes. Eg. for the geometrical construction chapter the title block may be drawn in the first sheet only where as on the remaining sheets borders to be drawn before they are used for preparing drawings.

Drawing instruments

The following are the commonly used equipment in a drawing office.

Drawing board (Fig 1): Drawing board is one of the main item of equipment for Draughtsman. It is used for supporting the drawing paper/tracing paper for making drawings. It is made of well-seasoned wood strips of about 25 mm thick or masonite, free from knots and warping. It should be softer enough to allow insertion and removal of drawing pins. Two battens are fastened to the board by screws, in slotted joints. They prevent warping and at the same time permit expansion and contraction of the strips due to the change of moisture in the atmosphere.

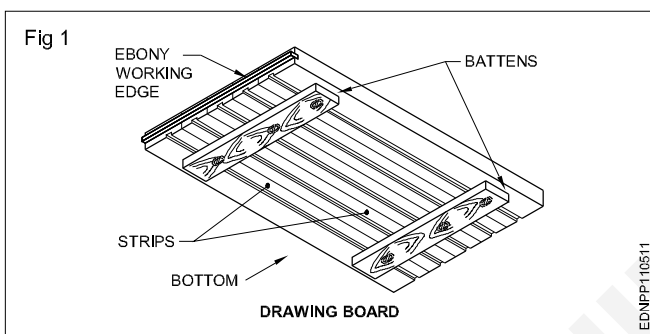

One of the shorter edges of the drawing board is provided with an "ebony edge" (hardwood) fitted perfectly straight.

Standard drawing boards are designated as follows as per IS:1444-1989.

Sl. No.	Designation	Size (mm)
1	D0	1500 x 1000 x 25
2	D1	1000 x 700 x 25
3	D2	700 x 500 x 15
4	D3	500 x 350 x 15

The working edge (ebony) must be straight.

Now-a-days drawing boards are available with laminated surfaces. The flatness can be checked by placing a straight edge on its surface. If no light passes between them, the surface is perfectly flat.

'T' Square: It is of 'T' shape, made of well-seasoned wood. It has two parts., head/stock and blade. One of the edges of the blade is the working edge. The blade is screwed to this head such that the working edge is at a right angle to the head. (Fig 2a)

The standard 'T' square is designated as follows with dimensions shown in mm; as per IS:1360-1989.

Sl. No.	Designation	Blade length
1	T0	1500
2	T1	1000
3	T2	700
4	T3	500

The 'T' square is used with its head against the ebony edge of the drawing board to draw horizontal lines, and parallel lines and to guide/hold the set squares, stencils etc.

Fig 2b shows how the 'T' square is used.

'T' square should never be used as a hammer or as a guide for trimming papers.

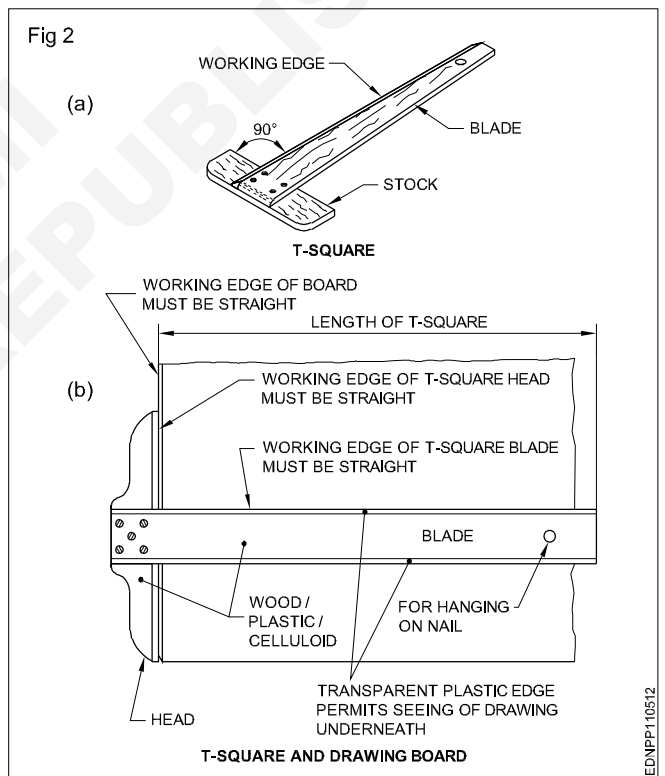

Drafting in the machine (Fig 3): It serves the functions of a Tee square, set square, protractor and scale. They come in different sizes and have a pattern called the 'Pantograph' type. It is fitted on the top left side, edge of the drafting board, mounted on an adjustable frame or table. It requires a large area of working place. The angle of the drafting board can be adjusted by the pedal operating system. There are two counterweights to balance the angular position of the board and the drafting head. It is more suitable for the production drawing office.

Fig 3

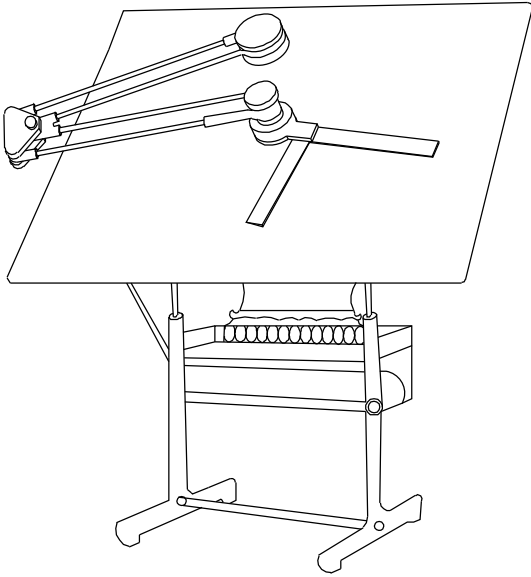

EDNPP110513

On the other end, a protractor head H with swivelling and locking arrangement is fitted with two scales at right angles.

The protractor head has a spring-loaded clutch relieving handle, which rotates and locks at 15° intervals automatically. For setting any angle other than multiples of 15°, the clutch spring is released and by rotating the centre knob, the zero line is set to the required angle and the friction clutch knob is tightened. It is capable of rotating 180°, thereby any angle can be set.

The scales are bevelled on both sides, graduates to 1:1 & 1:2. They can be reversed with the help of dovetail slide fitting.

There is a fine adjusting mechanism on the drafting head to set the scale parallel to the edge of the board. The scales also can be adjusted if there is an error in measuring 90° between them.

The mini drafter is an important device used for making drawing quickly & accurately. This instrument has the combination of T-square, set square, protractor and scales, it helps to draw the drawings at a faster rate. (Fig 4, 5 & 6)

Fig 4

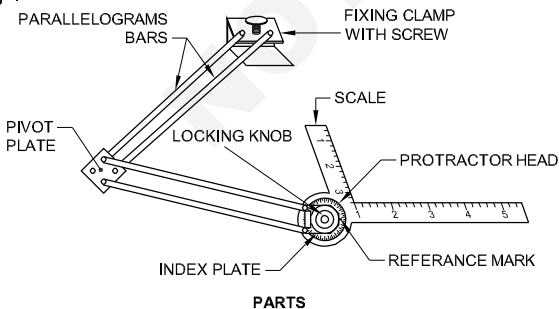

EDNPP110514

Fig 5

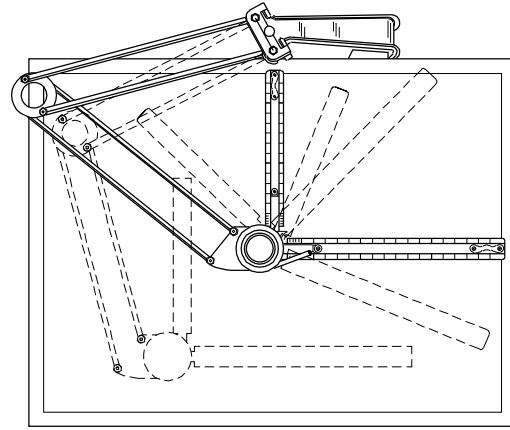

HOW MINI DRAFTER CAN BE ADJUSTED?

EDNPP110515

Fig 6

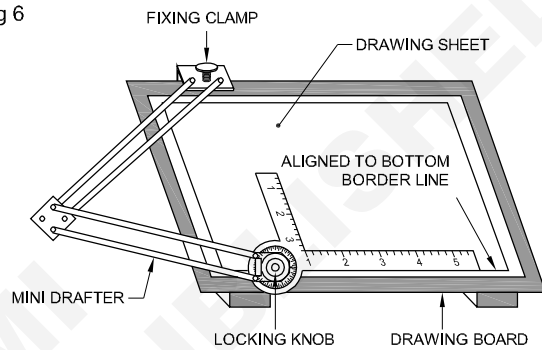

HOW TO FIX MINI DRAFTER

EDNPP110516

Erasing shield: When, on a drawing, if a part of a line or some lines among many other lines needs to be erased or modified, in a normal way erasing will damage the other nearby lines. In such a situation an erasing shield is effectively useful. It is a thin metallic sheet having small openings of different sizes and shapes. A suitable opening is aligned to the line to be erased and the line is removed by the eraser. (Fig 7)

Fig 7

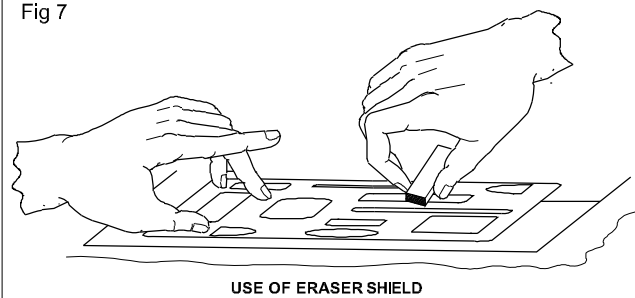

USE OF ERASER SHIELD

EDNPP110517

Set square (IS:1361-1988): Transparent celluloid /Plastic set squares are preferred and are commonly used rather than ebonite ones. They are two in number, each having one corner with 90°. The set square with 60° & 30° of 250 mm long and 45° of 200mm long is convenient for use. (Fig 8)

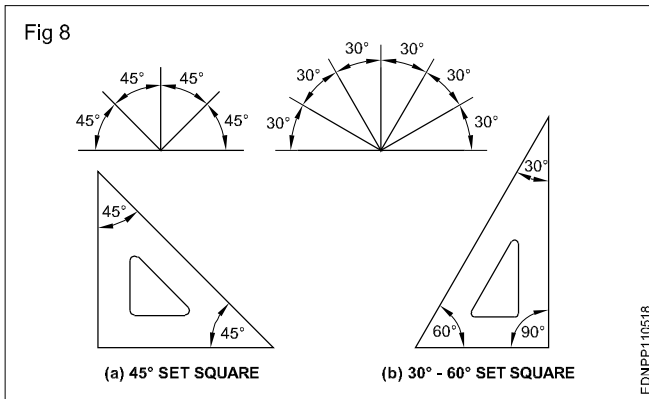

Scales: Scales are used to transfer and or measure the dimensions. They are made of wood, steel, ivory, celluloid or plastic, stainless steel scales are more durable. different types of scales used are shown in Fig 9. They are either flat, bevel-edged or triangular cross-sections. Scales of 15cm long, 2cm wide or 30cm long 3.5cm wide are in general use.

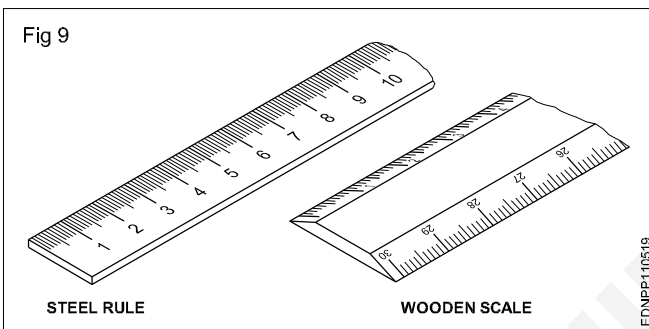

Protractor: A protractor is an instrument for measuring angles. It is semi-circular or circular and is made of a flat celluloid sheet.

The angles can be set or measured from both sides, aligning the reference line and point '0' with the corner point of the angle.

Figure 10 shows how to read or set the angle. A protractor can also be used to divide a circle or draw sectors.

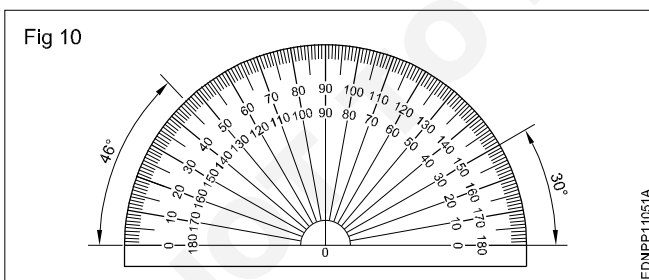

French curves (Fig 11)

These are made in many different shapes, normally come in sets of 6, 12, 16 etc. French curves are best suited to draw smooth curves/arcs (which cannot be drawn by a compass) with ease. To draw a smooth curve using a french curve first set it by trial against a part of the line to be drawn, then shift it to the next portions.

Fig 12 shows how to use the french curve and draw smooth curves. They are made of transparent celluloid (no bevel edge).

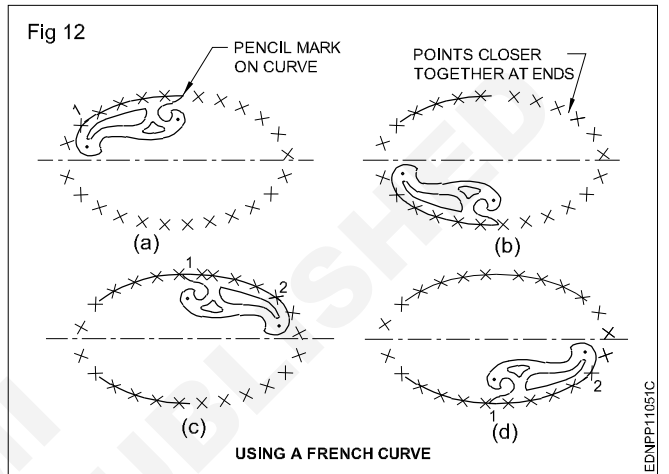
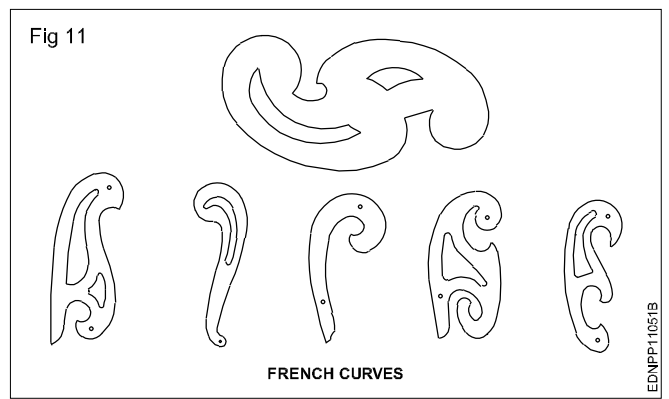

An instrument box contains the following: (Fig 13a to h)

- Large compass (with attachment facility) (a)
- Large divider (b)
- Bow compasses(pencil/ink), bow divider (c)
- Lengthening bar (d)
- Pen point for attachment (e)
- Screwdriver (f)
- Lead case (g)
- Liner (h)

Large compass (Fig 14): It has a knee joint in one leg that permits the insertion of a pen or pencil point or attaching a lengthening bar with a pen or pencil point attached to it. It is used for drawing large circles/arcs and also for taking large measurements.

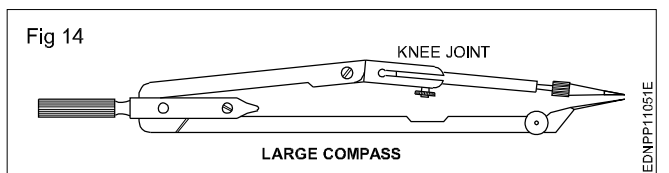

As a rule, while drawing concentric circles, small circles should be drawn first before the centre hole gets worn.

Large divider: It is used to transfer dimensions and divide lines into several equal parts. Divider with adjustable joints is preferable rather than plain legs. (Fig 15)

Fig 13

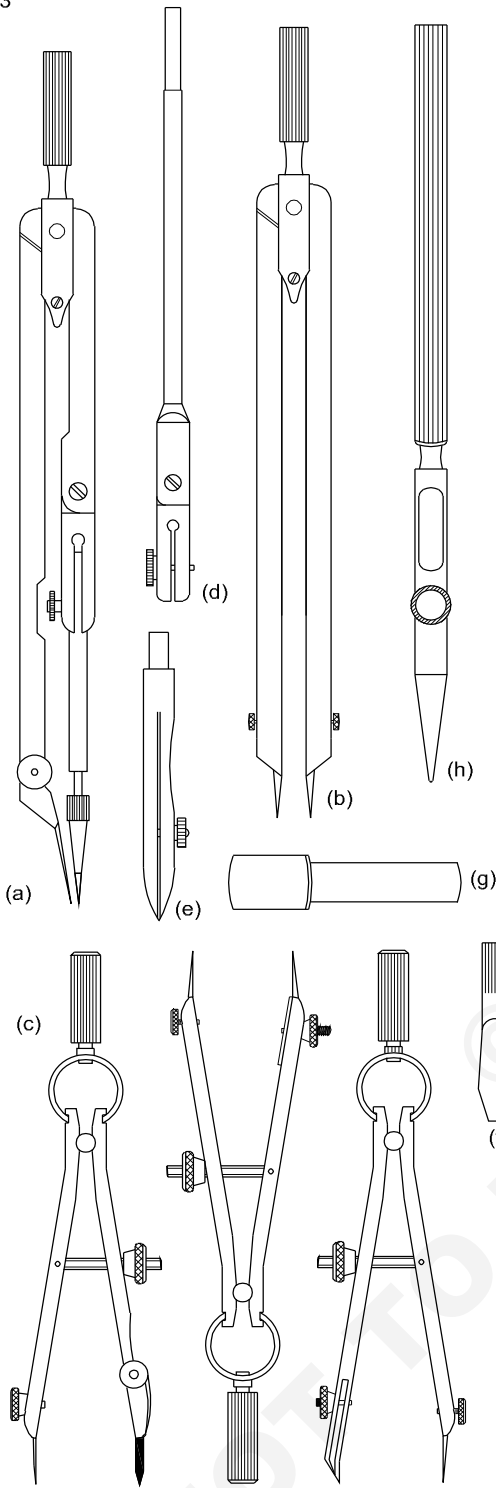

EDNPP11051D

Fig 15

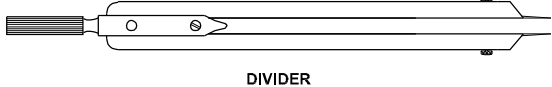

EDNPP11051F

Bow instruments: Bow pencil and bow pen compass are used for drawing circles of approximately 25 mm radius. A bow divider is used for marking or dividing smaller spaces. There are two types (i) Integral legs with spring action (ii) two legs are held with a curved spring on top with a handle on it.

Fig 16 shows different types of bow instruments. Adjustments should be made with the thumb and middle finger.

Fig 16

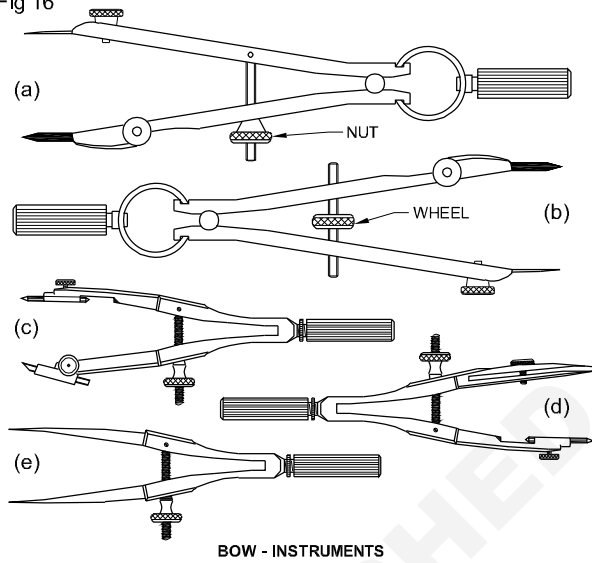

EDNPP11051G

Drop spring bow pencil and pen (Fig 17): Drop spring bow pencil and pen are designed for drawing multiple identical small circles. Example: rivet holes, drilled/reamed holes. The central pin is made to move freely up and down through the tube attached to the pen or pencil unit.

Fig 17

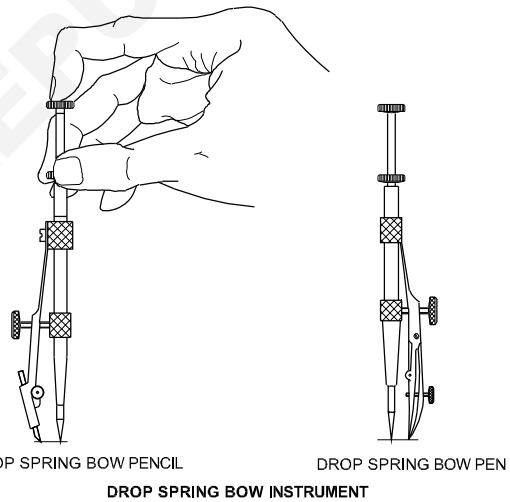

EDNPP11051H

Inking pen or liner or ruling pen (Fig 18): It is used to ink the straight lines drawn with the instruments but never for freehand lines or lettering.

Fig 18

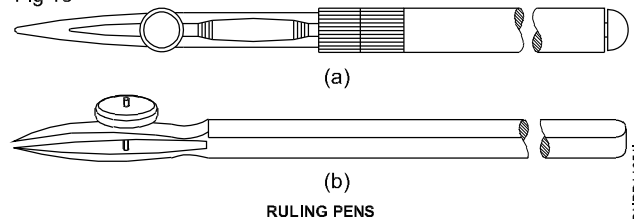

EDNPP11051I

Lengthening bar (Fig 19): To draw larger circles, it is fitted to the compass. The pencil point or pen point is inserted into its end.

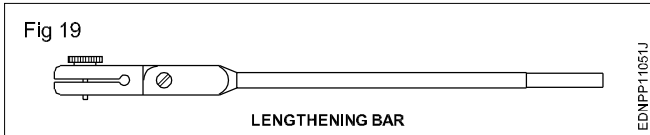

Replaceable spare pencils, pens and needle points for the compass are available in the instrument box.

Screwdriver (Fig 20): Used for adjusting the screws of the instruments.

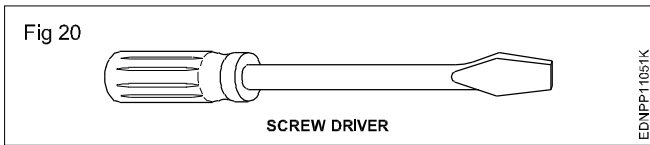

Lead case (Fig 21): Lead case is the box for holding the pencil leads.

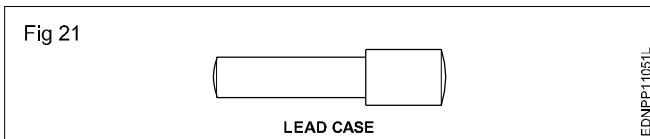

Pin, Clip, Cello tape: Drawing sheet should be fastened onto the drawing board firmly temporarily so that it does not shake during preparing the drawing. For this purpose, the pins, clips and cello tapes are used (Fig 22)

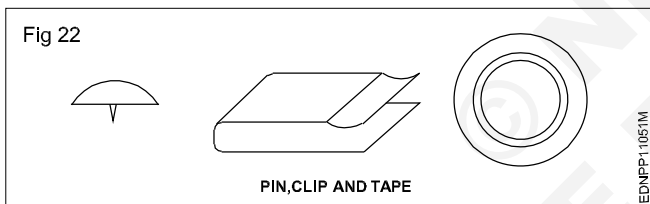

Pencils, Grade and Selection (Fig 23)

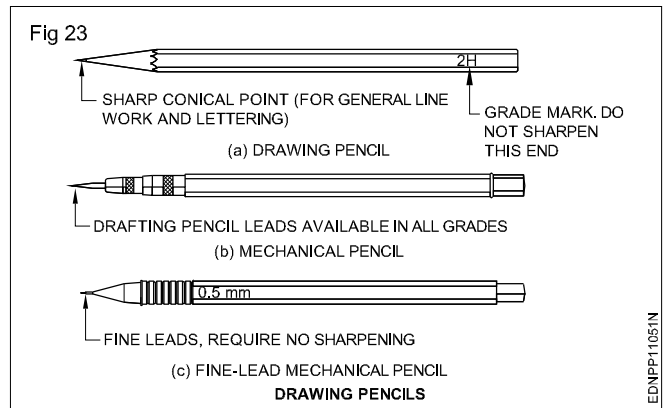

Grades of pencils: Pencils are graded according to the hardness or softness of the lead.

The hardest pencil is 9H grade and the softest pencil is 7B grade. The selection of the grade of pencils depends on the type of line work required and the paper on which it is used.

Softer lead pencils are used to produce thicker and darker line work, but they wear out quickly. Medium grades of H and 2H are used for general line work as well as for lettering.

Selection of pencils: Pencil grades vary from one brand to another brand. Select the grades of the pencil depending upon the type of line work. For construction lines, you can choose 2H or 3H, for lettering and object lines grade H pencils. In general H, HB and 2H are used.

H - medium-hard

HB - medium-soft

2H - hard

Now-a-days automatic (Mechanical) pencils or clutch pencils are available in different sizes (lead dia. 0.3, 0.5, 0.7 or 0.9). Leads can be replaced as per the required grade of hardness. They produce lines of uniform width without sharpening.

Lines - Types and applications in drawing

Drawings are made up of different types of lines. Just a language with alphabet and grammar.

Lines of different thicknesses and features are used for specific use. (Fig 1 and 2)

Technical drawings are drawn with different types of lines. By proper choice and application of lines, product features can be correctly defined in a drawing. Different types of lines recommended for specific applications are given in Table 1.

Table 1
Types of lines and their application

Lines	Description	General applications See figure and other relevant figure
Fig 1	Continuous thick	A1 Visible outlines A2 Visible edges
A _____ 0.5	Continuous thin (straight)	B1 Imaginary lines of intersection B2 Dimension lines B3 projection lines or extension line B4 Leader lines B5 Hatching B6 Outlines of revolved sections in place B7 Short centre lines B8 Thread line B9 Diagonal line
B _____ 0.2		
C _____ 0.2	Continuous thin free hand	C1 Limits of partial or interrupted views & sections, if the limit is not a chain thin
D _____ 0.2	Continuous thin (Straight) with zig-zags	D1 Line (See figures)
E - - - - - 0.3	Dashed thick	E1 Hidden outlines E2 Hidden edges
F - - - - - 0.2	Dashed thin	F1 Hidden outlines F2 Hidden edges
G - - - - - 0.2	Chain thin	G1 Centre lines G2 Lines of symmetry G3 Trajectories
H - - - - - 0.3	Chain thin, thick at ends & changes of direction	H1 Cutting planes
J - - - - - 0.5	Chain thick	J1 Indication of lines or surfaces to which a special requirement applies
K - - - - - 0.2	Chain thin double-dashed	K1 Outlines of adjacent parts K2 Alternative and extreme positions of movable parts K3 Centroidal lines K4 Initial outlines prior to forming K5 Parts situated in front of the cutting plane
<p>1 This type of line is suited for production of drawings by machines.</p> <p>2 Although two alternatives are available, it is recommended that on any one drawing, only one type of line be used.</p>		

In the above range, for craftsmen, 0.5 is preferred. Table 2 shows the 0.5 line range and other lines under this range.

The numbers on the right side of the lines refer to the line thickness in mm.

Table 2

Fig 2		
A		0.5
B		0.2
C		0.2
D		0.2
E		0.3
F		0.2
G		0.2
H		0.3
J		0.5
K		0.2

All the views of a component drawn to one particular scale should have the same range of line thickness.

Types of lines: Ten types of lines are used in general engineering drawing as per IS:10714-1983. Which first four types of lines are continuous lines of both thick and thin. (Type A to D)

A continuous thick line (A-type) is used for drawing visible outlines (A1) and visible edges (A2). (Fig 3) These lines are also called object lines

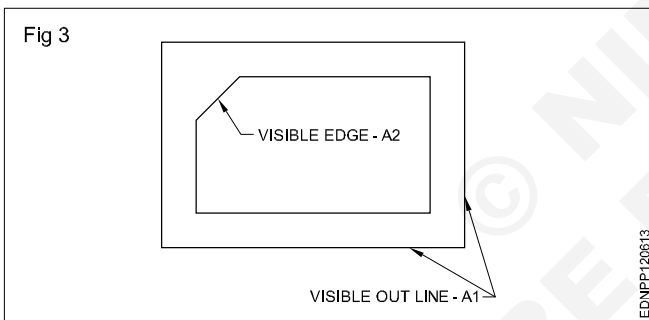

Continuous thin lines (B type): Continues thin lines are used for many applications as stated in Table 1. A few applications of B types of lines are shown in Fig 4.

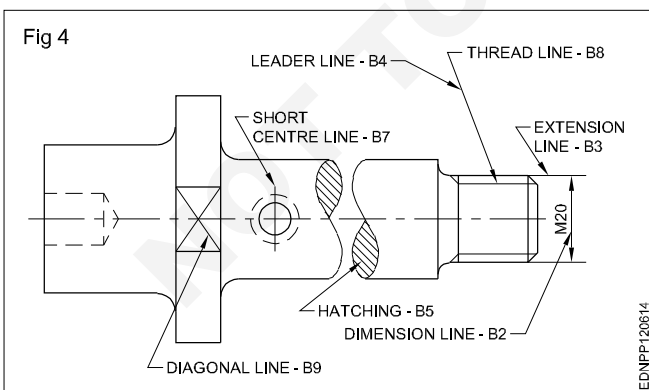

A leader line - B4 (Fig 4): A leader line is a line referring to a feature (dimension, object, outline etc). A leader line should terminate.

- with a dot
- with an arrow head
- without a dot or arrow head (Fig 5)

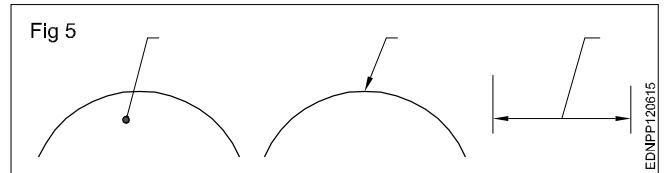

Hatching lines (B5): Hatching lines are the lines inclined parallel lines. The minimum space between these lines should be more than twice the thickness of the heaviest line in the drawing. It is recommended that these spacings should never be less than 0.7 mm. (Fig 4)

For showing the limits of partial or interrupted views and sections continuous thin freehand lines (C1) or continuous thin straight lines with zig-zag (D1) are used. (Fig 6)

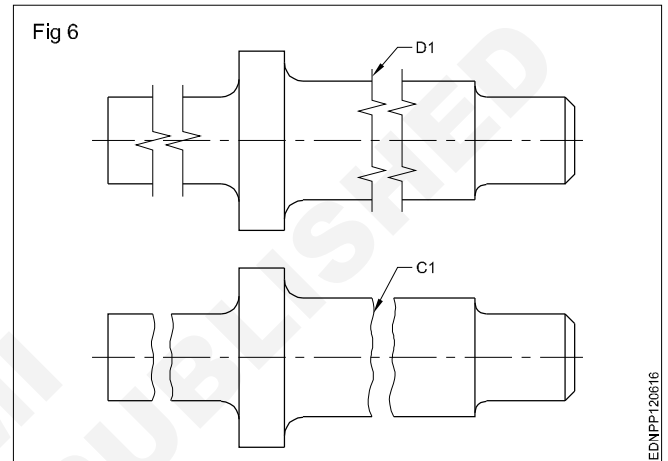

Lines of type E to K in Table 1 are of the non-continuous type. Some of these are thin and some are thick. For hidden lines both thick and thin dashes (E & F type) are available, it is recommended that on anyone drawing, only one type of (Thick or thin) line be used. (Fig 7)

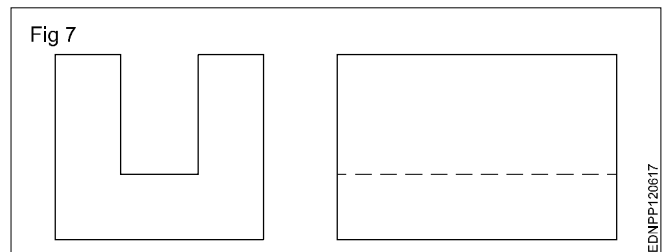

Chain lines (Thin): Chain lines are used for drawing centre lines of circles, cylinders etc. Same lines are also used to show the axis of symmetry in symmetrical objects. The line of symmetry is identified at its ends by two thin short parallel lines drawn at right angles to it. (Fig 8)

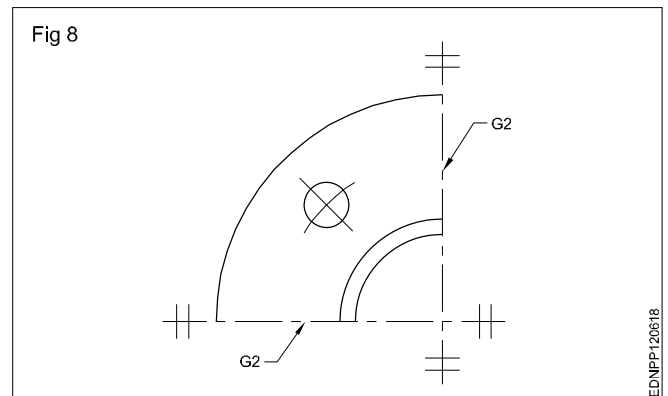

Another method of representing symmetrical shape is to extend the object lines beyond the axis of the symmetry. (Fig 9) In this case, the short parallel lines described above are omitted. The same lines are also used to show the repetitions of features of a component. (Fig 10)

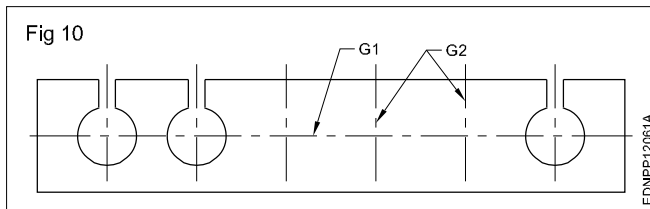
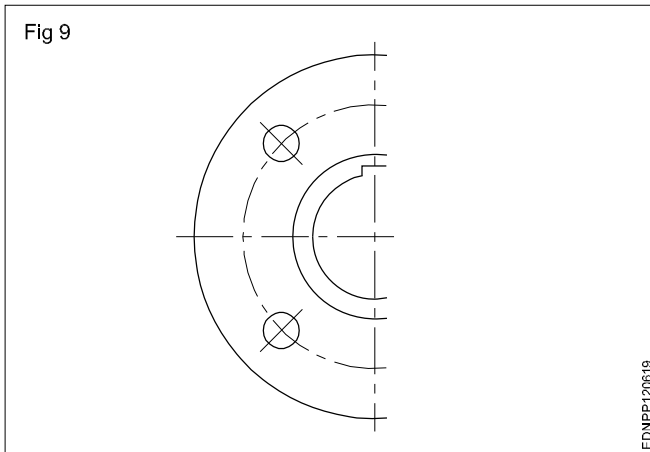

For drawing a sectional view, the plane of cutting is to be shown in another view. The cutting plane (H1) in Table 1 is drawn with a thin chain, thick at the ends and also at the places of direction change. (Figs 11 & 12)

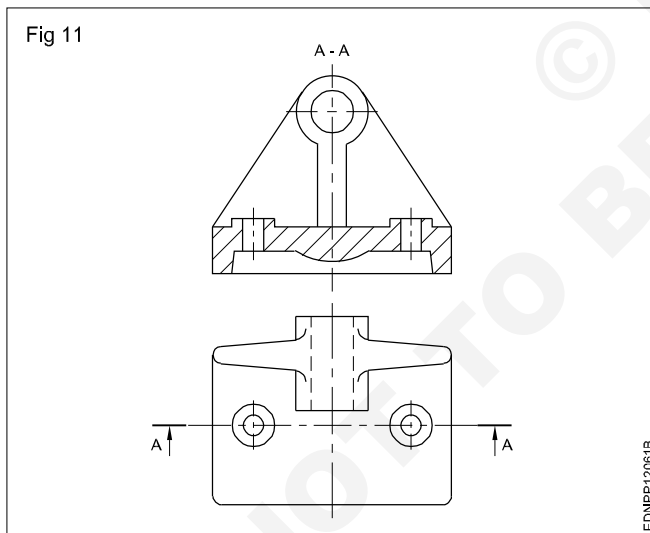

If thick chain lines (J1) in table 1 are drawn on a surface, it indicates some special treatment/application on that surface. (Fig 13)

Chain thin double dashed (K) lines are applied for the following:

- K1 - Outlines of adjacent parts (Fig 13)
- K2 - Alternative and extreme positions of moving parts. (Fig 13)

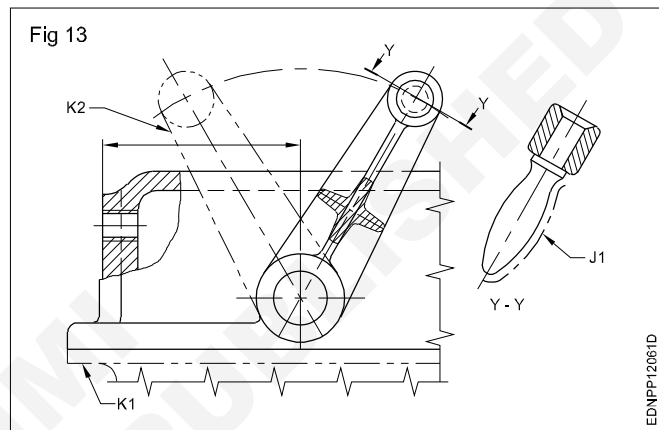
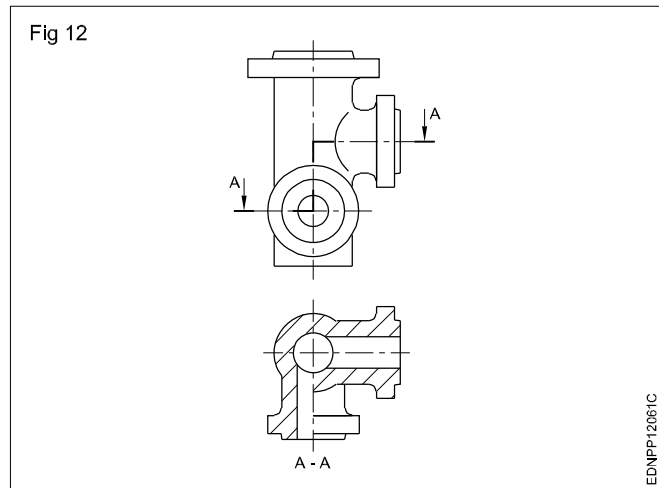

K3 - Centroidal lines (Fig 14)

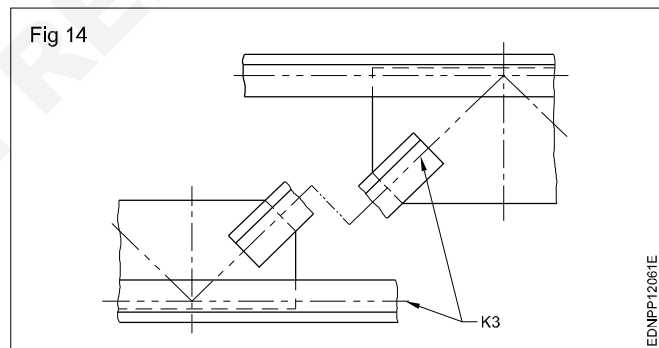

K4 - Initial outlines before forming (Fig 15)

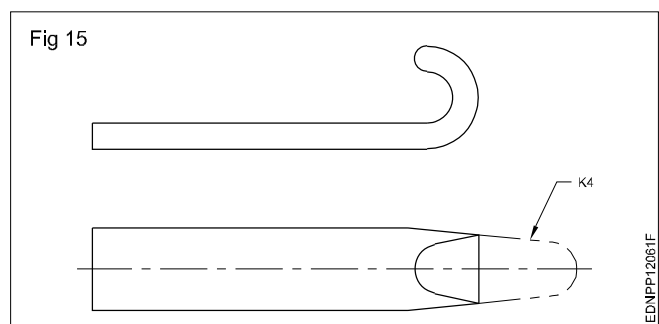

K5 - Parts situated in front of the cutting plane (Fig 16)

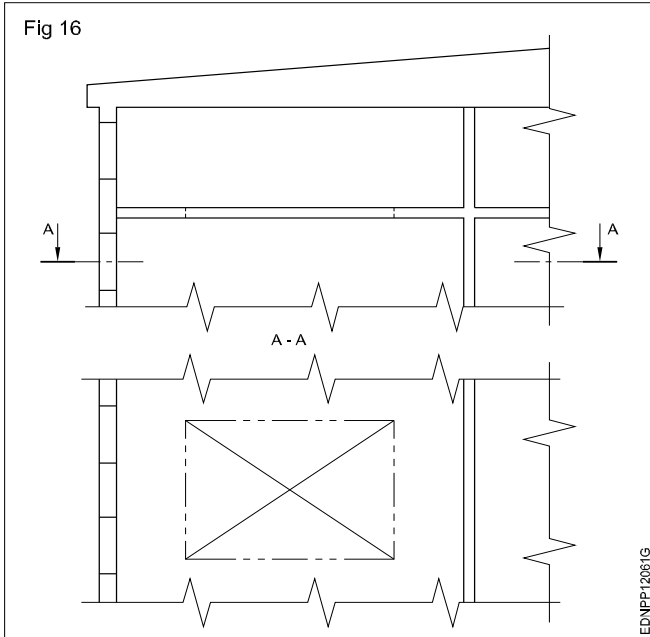

Lines - Drawing lines of a given length (straight, curved), drawing parallel lines, perpendicular lines and methods of division of line segment

There are a lot of ways to define straight and curved lines; the most elaborate way to define them is the following:

- A straight line is a succession of points that are aligned in the same direction. Or in other words, to go from one point to another, we never change direction. (Fig 17)

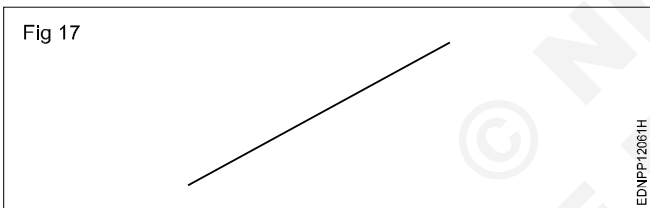

- On the contrary, the points of a curved line do change direction from one point to the next. (Fig 18)

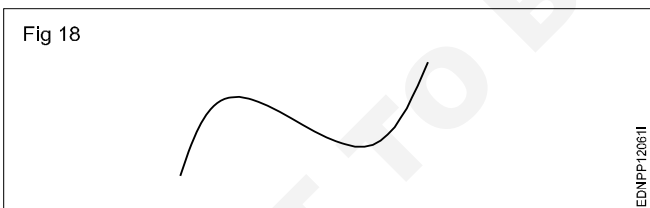

- If there aren't any obstacles, there are plenty of ways to do this...for example: (Fig 19 to 23)

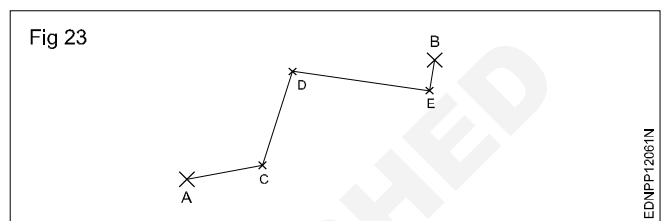
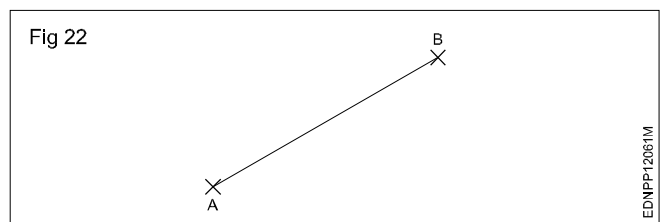
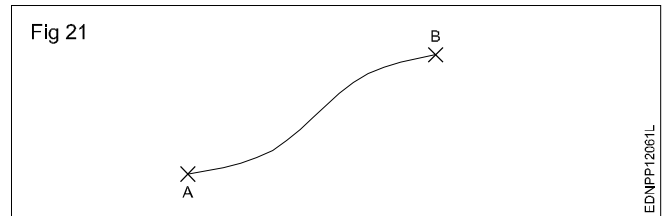
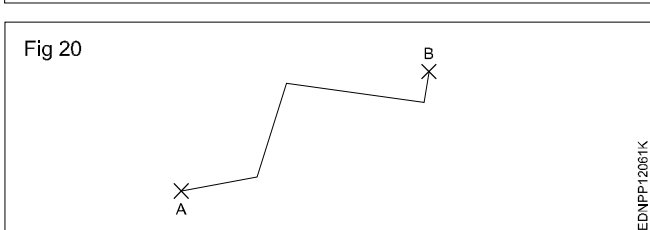
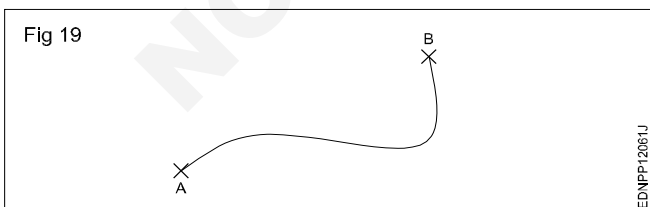

Tangent line (Fig 24)

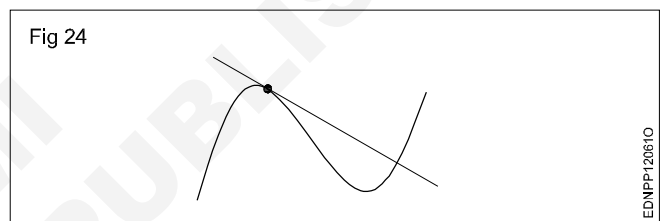

4 Easy ways to draw curved line (Fig 25)

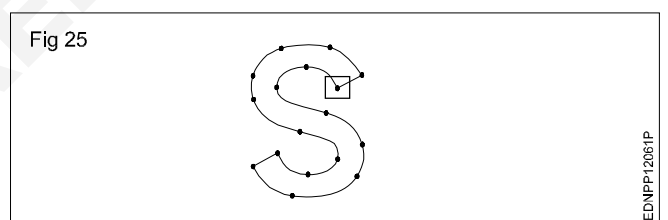

Drawing curved dashed line (Fig 26)

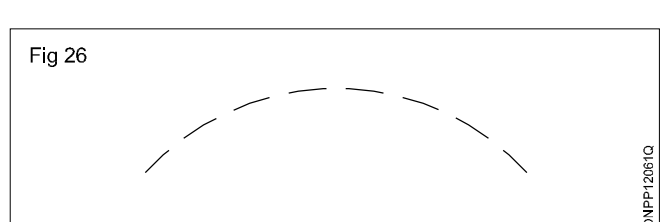

Exercise 1

How to draw six horizontal parallel lines of 50 mm long with 10 mm intervals (Fig 1).

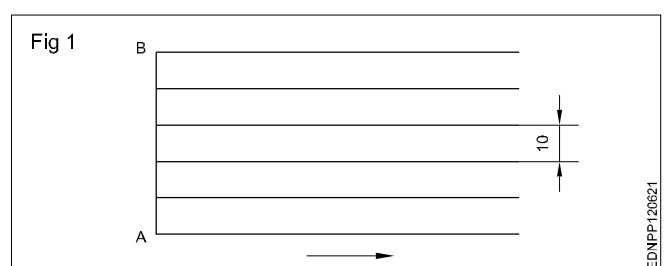

Use a sharpened conical point pencil.

Keep the pencil slightly inclined towards the direction of the movement.

While drawing rotates the pencil to keep the constant thickness.

Maintain uniform pressure on the lead of the pencil.

Exercise 2

How to draw six vertical parallel lines of 50 mm length with 10 mm intervals (Fig 2).

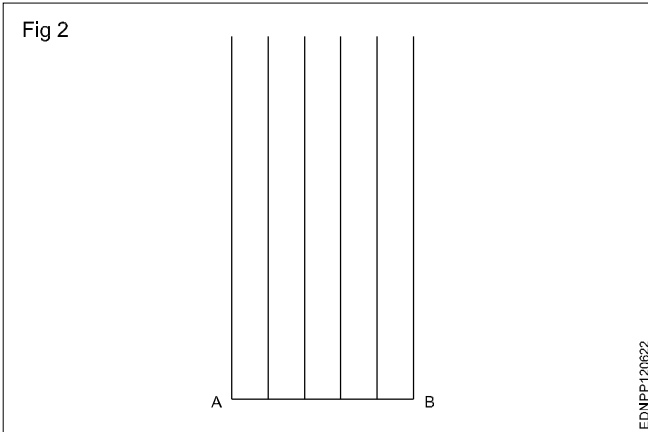

Draw the vertical lines from bottom to top.

Exercise 3

How to draw 45° inclined lines (Fig 3).

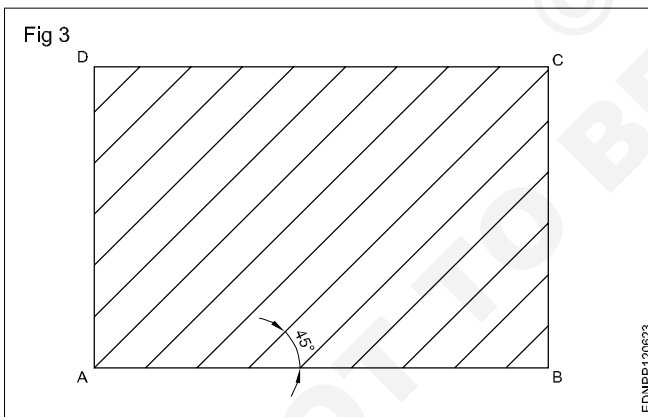

Draw lines from bottom to top.

Sketch by free hand

Sketch the following practice No.1 to 3 in A3/A4 sheets.

Practice

1 To draw horizontal thick and thin lines. (Fig 1)

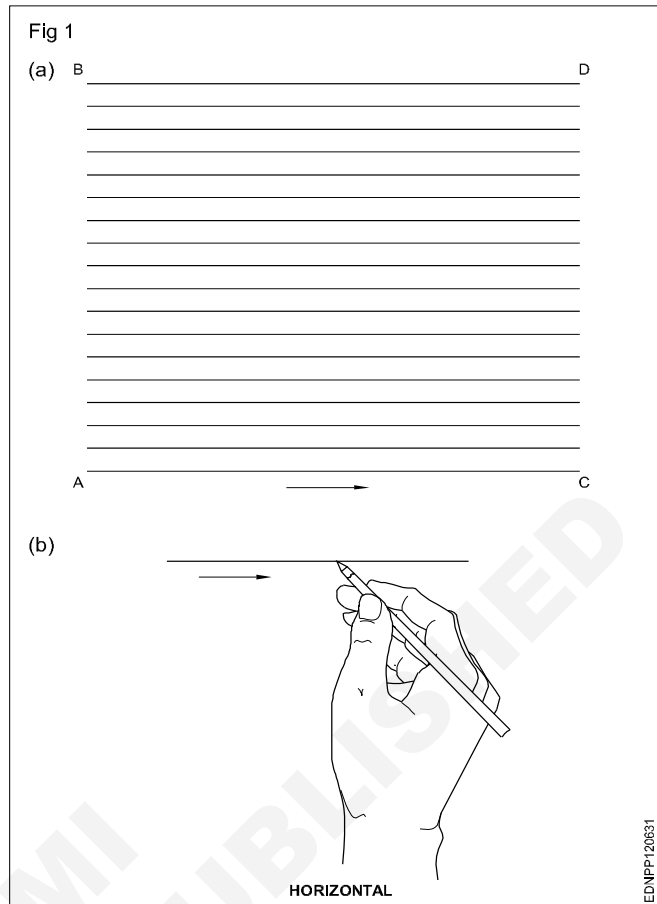

2 To draw vertical thick and thin lines. (Fig 2)

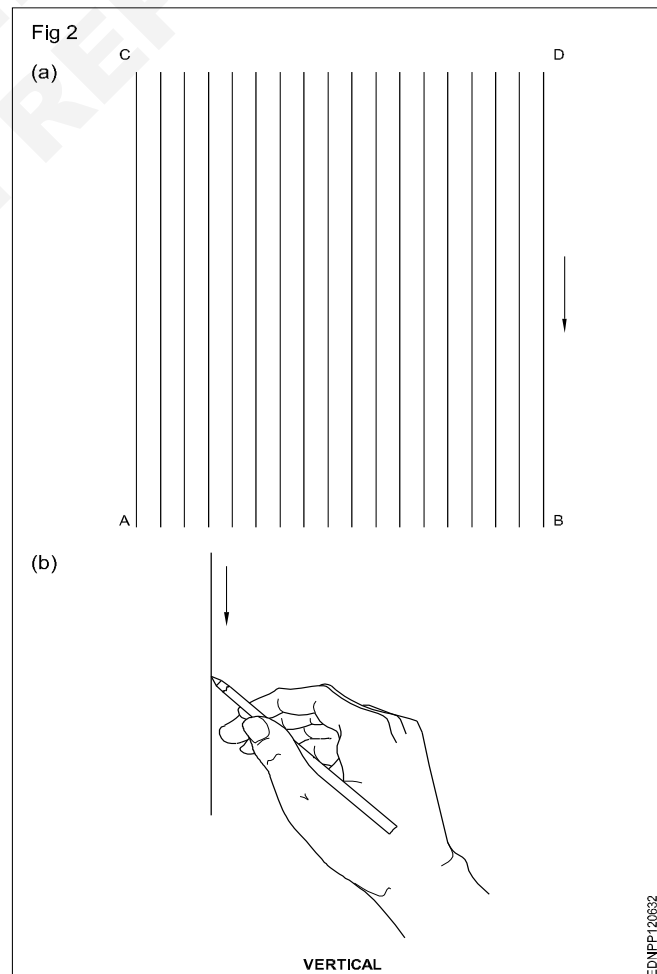

3 Sketch the inclined lines as shown in figure with thick and thin lines. (Fig 3)

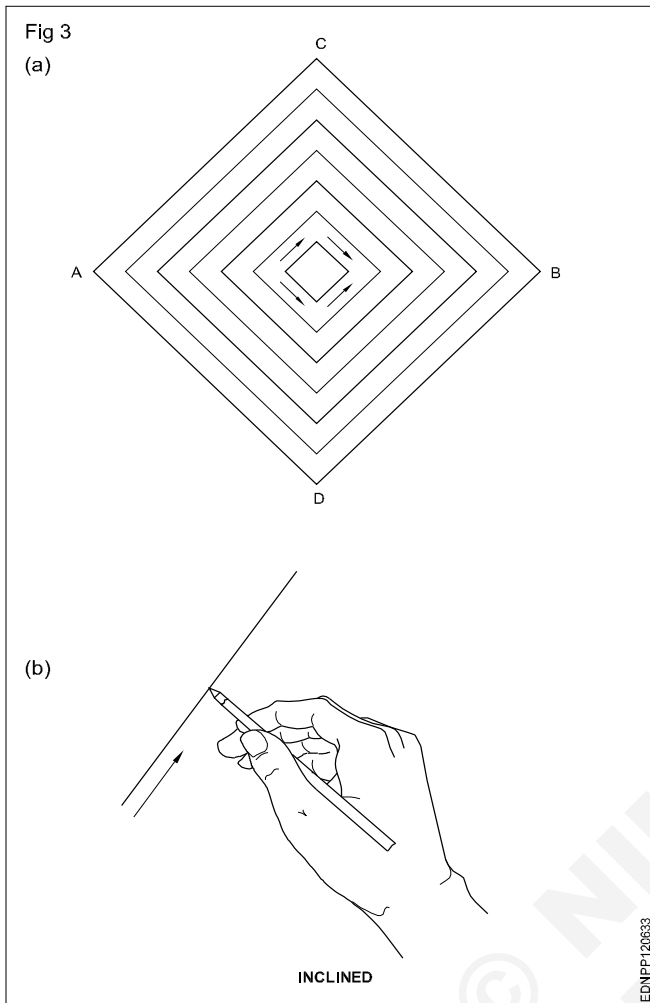

Types of lines

A point represents a location in space, having no width or height. It is represented by drawing the intersection of lines or a dot. (Fig 4)

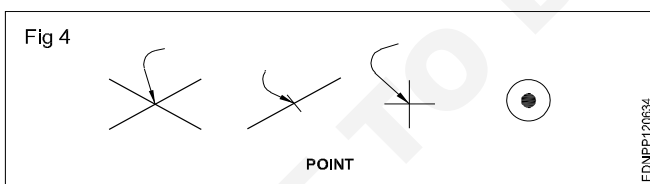

A line is the path of a point when it moves. It has no thickness and is of two types:

- i Straight line and ii Curved line

Straight-line: It is the path of a point when it is moving in a particular direction. It has only length and no width. (Fig 5) Also, a straight line is the shortest distance between two points. Straight lines, depending on their orientation are classified as Horizontal, Vertical Inclined or Oblique lines.

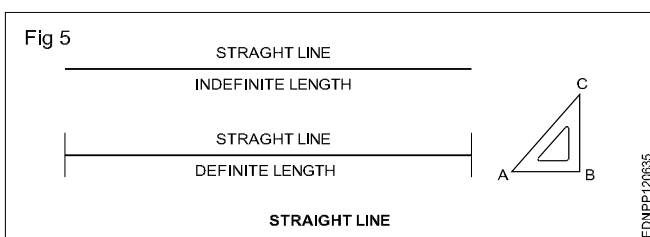

Horizontal line (Fig 6): Horizontal lines are those which are parallel to a horizontal plane. An example of the horizontal plane is the surface of still water. (Fig 6)

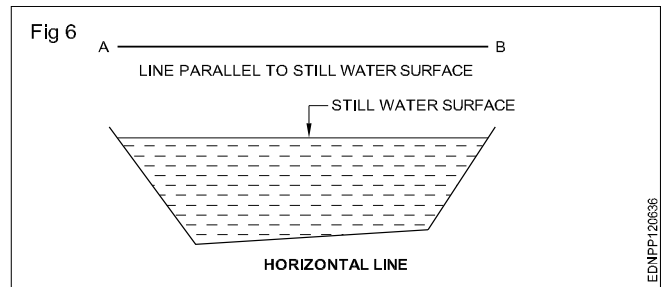

Vertical line (Fig 7a): Lines that are perpendicular to horizontal lines are called vertical lines. It can be treated as a line along the plumb line of the plumb bob or parallel to a plumb line. (Fig 7b)

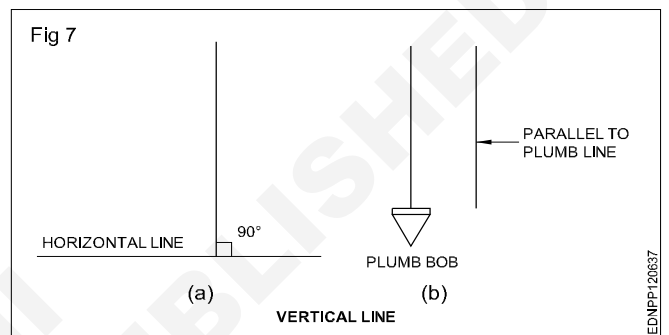

Inclined line or Oblique line: A straight line that is neither horizontal nor vertical is called an inclined line. (Fig 8)

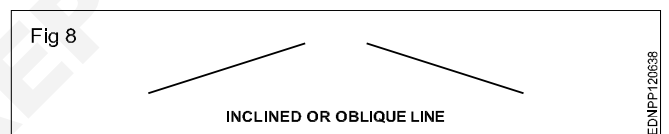

Curved line: It is the path of a point that always changes its direction. Examples of curved lines are shown in (Fig 9).

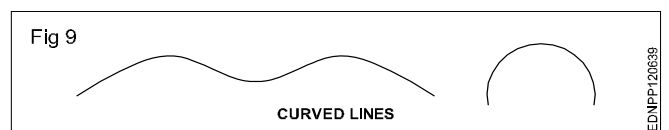

Parallel lines: They are the lines with the same distance between them. They may be straight lines or curved lines. Parallel lines do not meet when extended. (Fig 10)

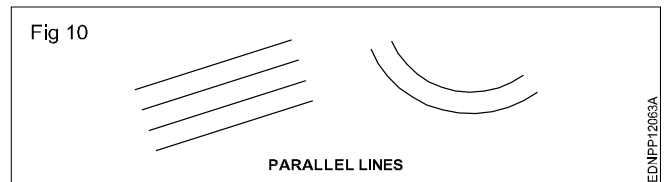

Perpendicular lines: When two lines meet at 90°, the two lines are said to be perpendicular to each other. One of the lines is called a reference line. (Fig 11)

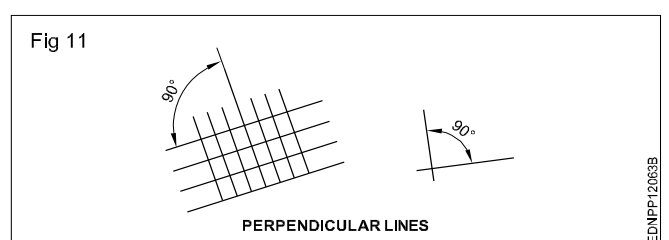

Free hand drawing of - Geometrical figures and blocks with dimension

Freehand sketching: Apart from making drawing using instruments, often craftsmen will be required to make drawings with their free hand.

Freehand sketching is the easiest method to express the shape of a piece part or a component by an engineer or craftsman.

Freehand sketches are not usually made to scale. However, they should be as nearly to the proportions as possible.

Cube (Fig 1)

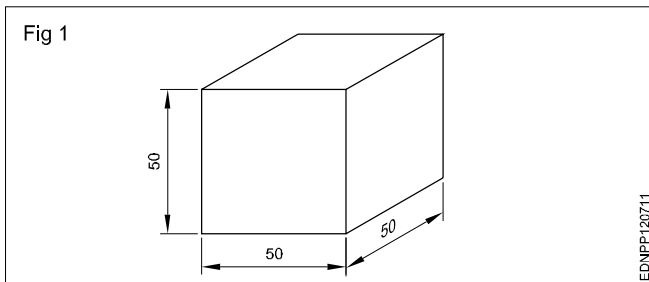

Square block (Fig 2)

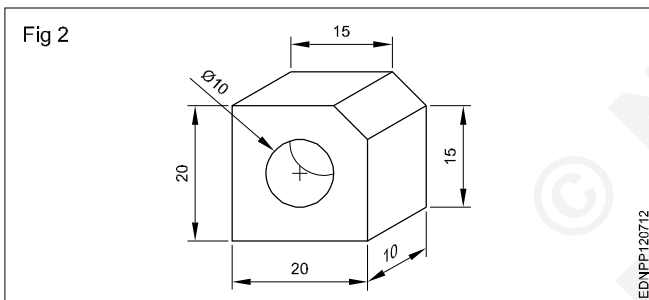

Rectangular block (Fig 3)

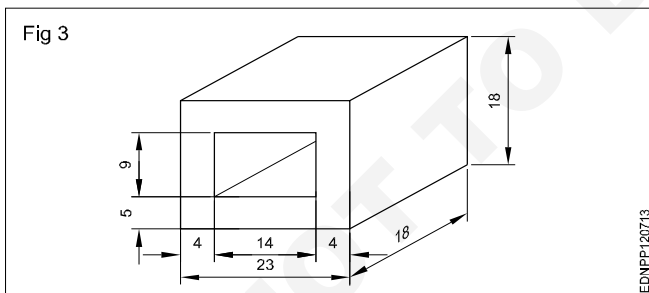

Cube block (Fig 4)

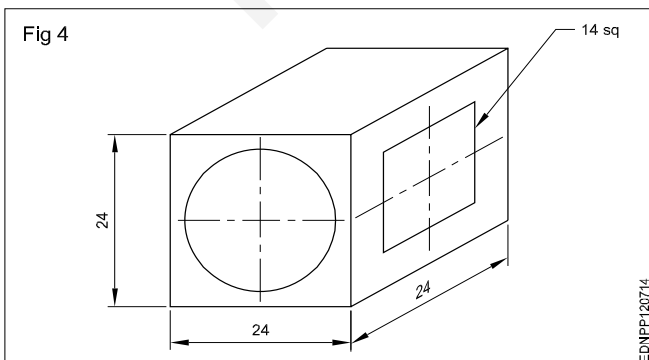

Cylinder (Fig 5)

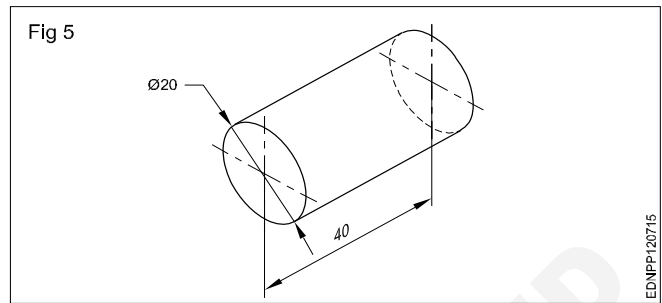

Materials for free hand sketching: A4 size sheet (preferably a pad instead of loose papers) pencils of soft grade. Example H, HB, and a good quality eraser are the only materials required. For drawing different darkness, the pencil points should be sharpened to a conical shape. Fig 6 shows some free hand sketches of different types of views.

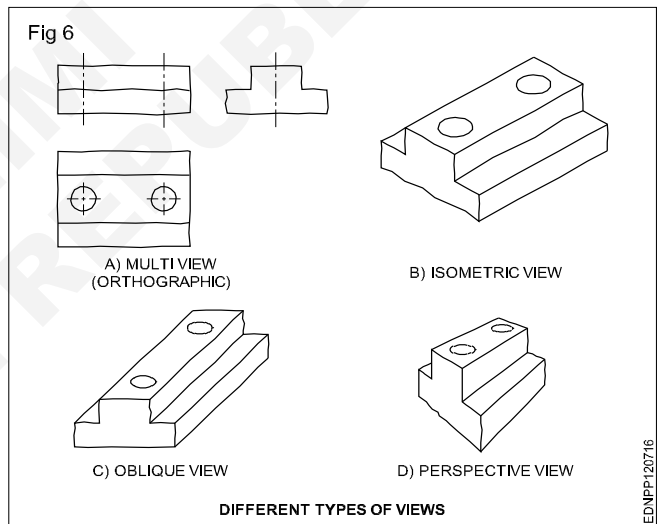

Procedure

Freehand drawing of solid figures, cubes, cuboids, cone, prism, pyramid, frustum of a cone with dimensions

Cube (Fig 1)

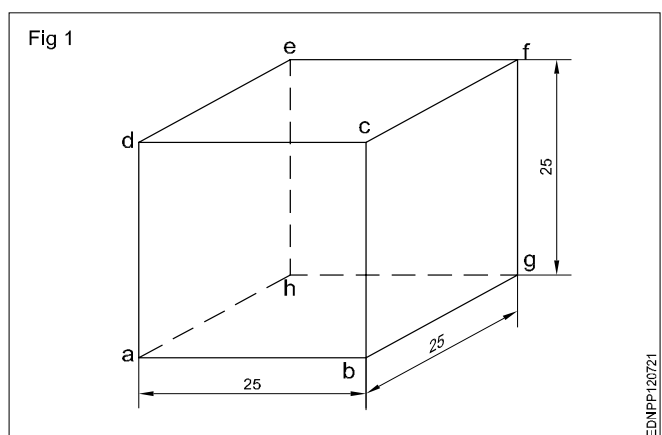

- Draw squares of a, b, c and d.
- Draw 30° from points b, c and d for the length of 25mm.
- Mark point g from b, f from c and e from d as shown in the figure.
- Joint all points.

Cuboid (Fig 2)

Draw the isometric drawing of a cuboid of base 60 mm x 40 mm and the height of 20 mm. (Fig 2)

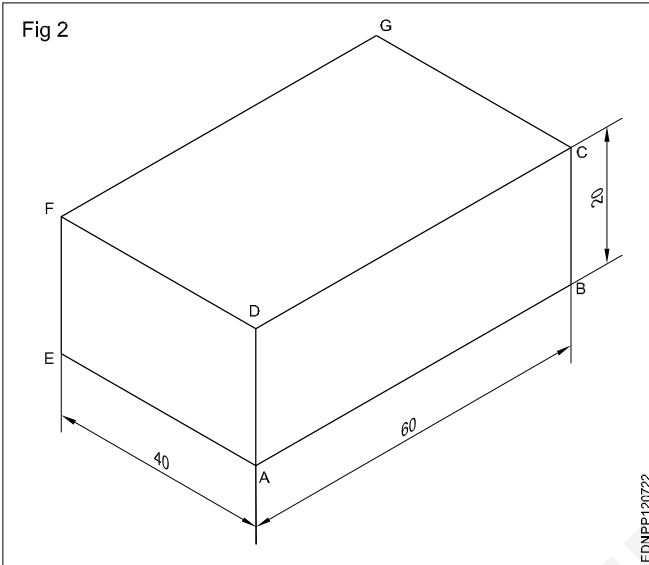

Draw the three isometric axes through the point 'A'.

- Mark AB = 60mm, AE = 40mm and AD = 20mm representing the three sides of cuboid.
- Draw two vertical lines EF and BC parallel to AD from points E and B respectively.
- Similarly, draw two more lines parallel to AB and AE to mark G's interesting point from F and C.
- Draw lines parallel to DC and FG. Draw lines parallel to DF and GC.
- Join all the points.

Cylinder (Fig 3)

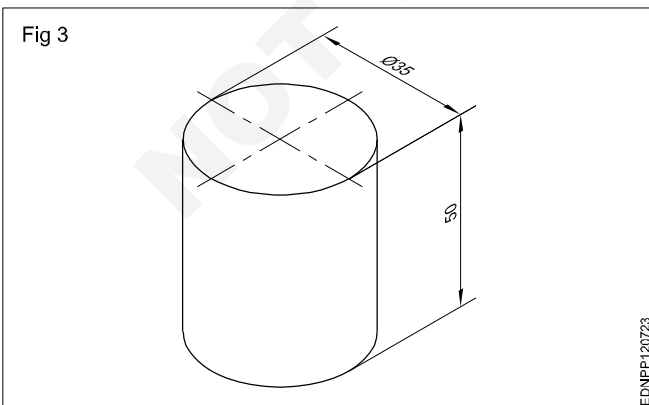

Rectangular prism (Fig 4)

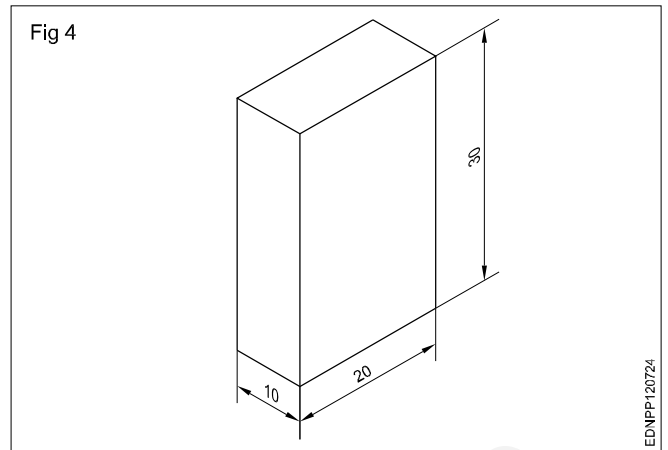

Square Prism (Fig 5)

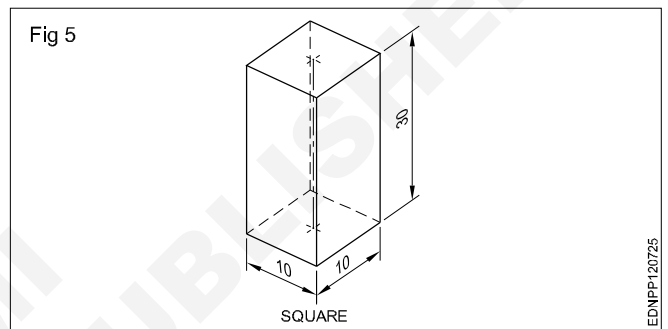

Triangular Prism (Fig 6)

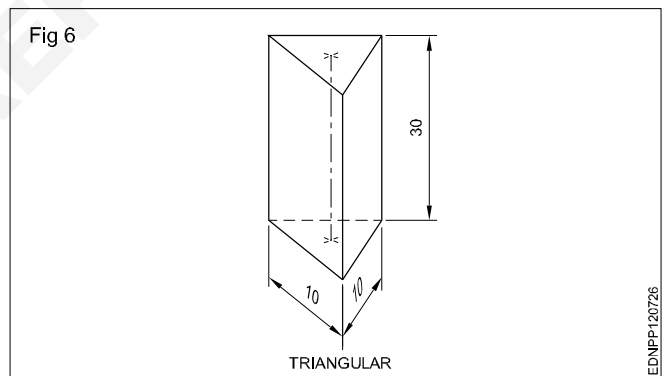

Pentagonal prism (Fig 7)

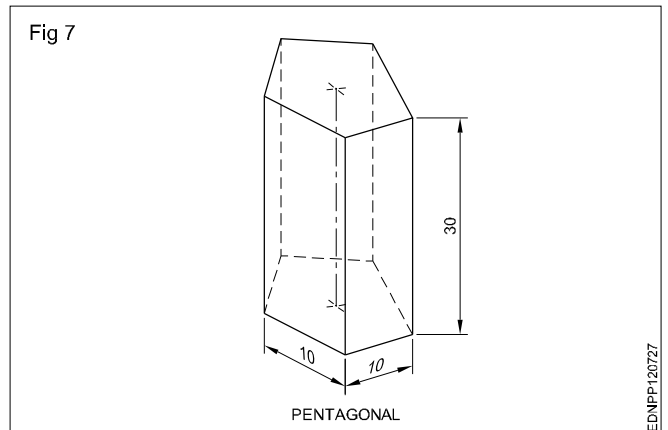

Hexagonal prism (Fig 8)

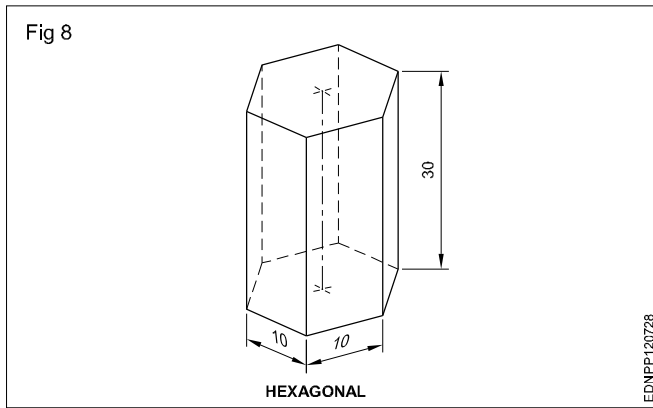

Cone: When a right-angled triangle revolves about one of its sides forming the right angle, a cone is generated. Cone forming has a circular face and a slant curved surface. (Fig 9)

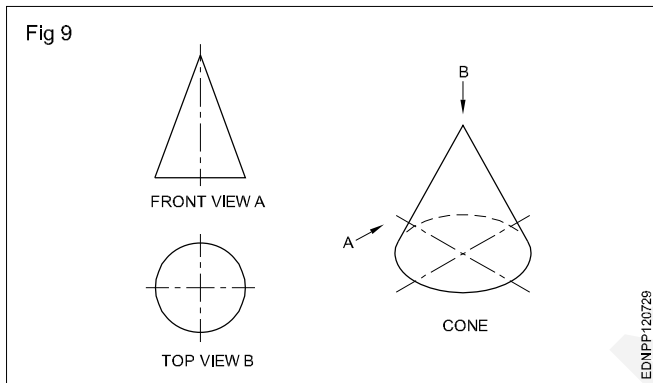

Pyramids: Pyramids are polyhedron solids having a base surface whose shape may be triangular, square or polygon and as many slant triangular faces as there are sides in the base. All the slant triangular faces join at a common point called APEX.

Similar to prisms, pyramids also are known by the shape of their base viz triangular, square, rectangular, pentagonal, hexagonal etc. The imaginary line joining the centre of the base to the apex is called the AXIS.

Fig 10 shows some pyramids and their views.

When a semi-circle revolves about its diameter a sphere is generated. A sphere has no flat surface. (Fig 11D)

Frustums: Pyramid/cone is cut parallel to the base and the top portion is removed. The remaining bottom portion is called the frustum of a pyramid/cone.

If the cutting plane is at an angle to the axis/base, the pyramids or cones are called "Truncated pyramids or cones".

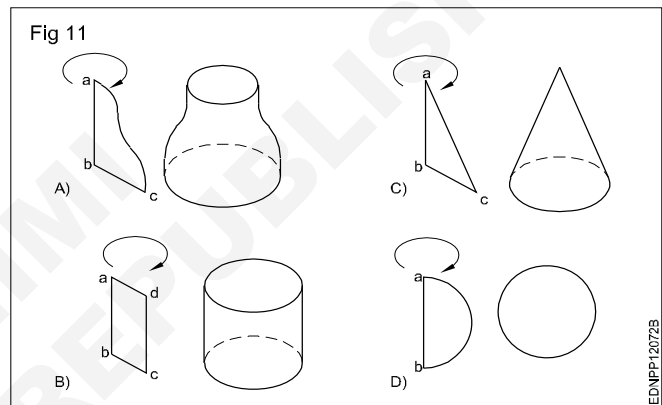
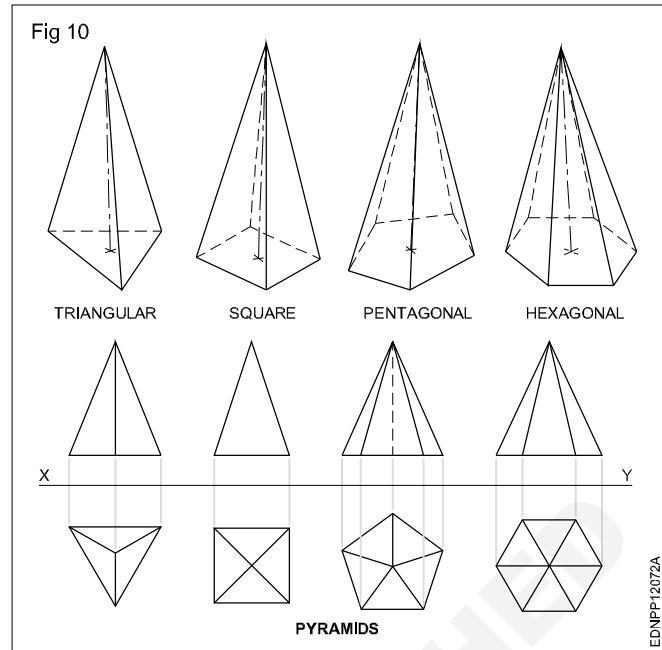
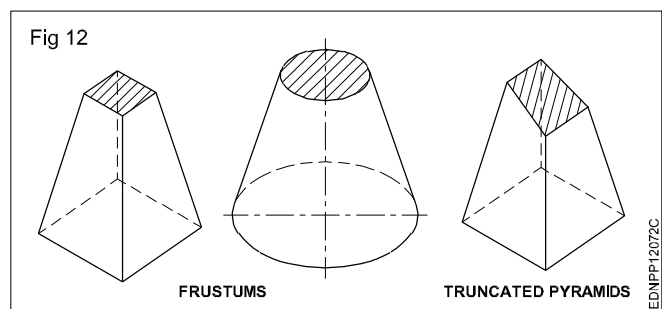
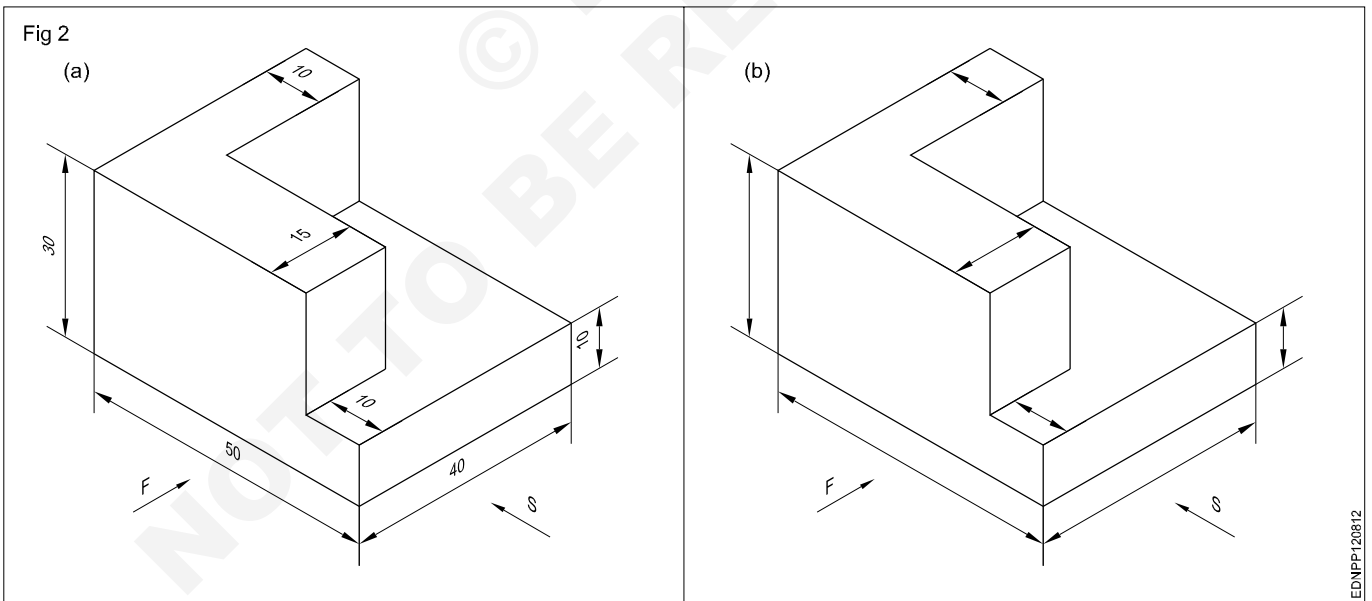
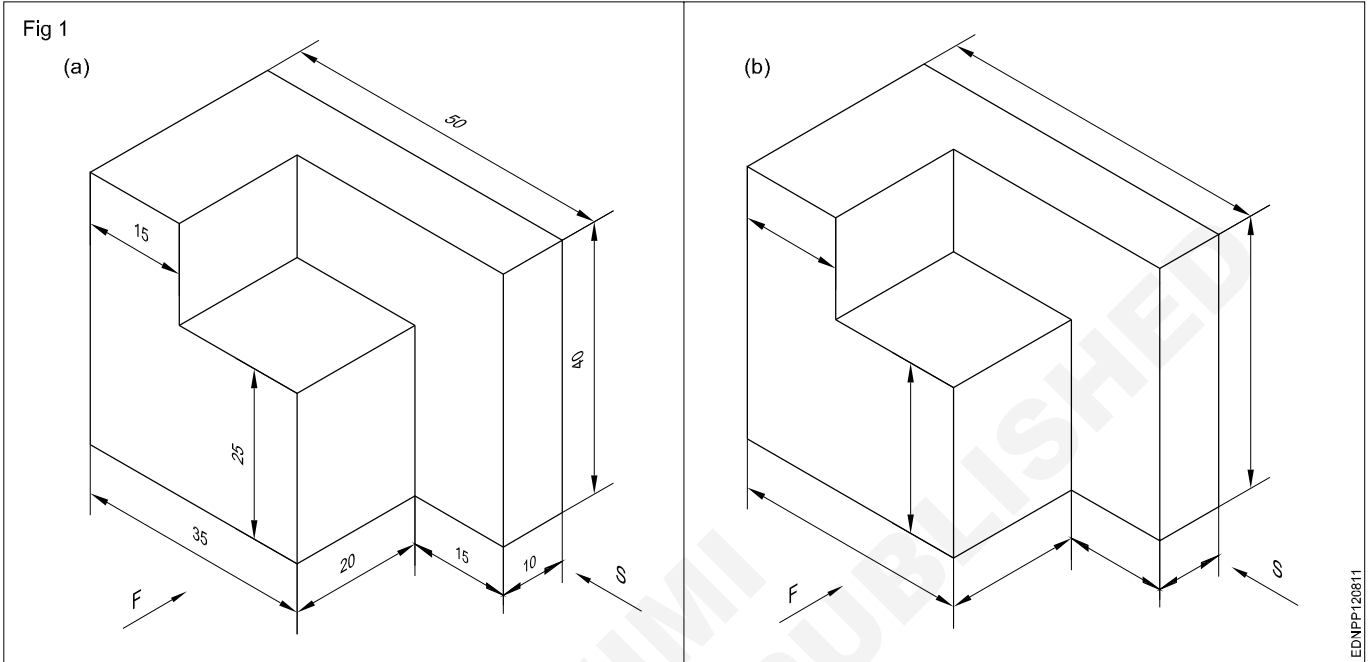

Fig 12 shows frustums and truncated pyramids.

All items we use are solids. Their shapes may confirm individual geometrical solids like prisms, cones or other combinations.



Free hand drawing of - Transferring measurement from the given object to the free hand sketches



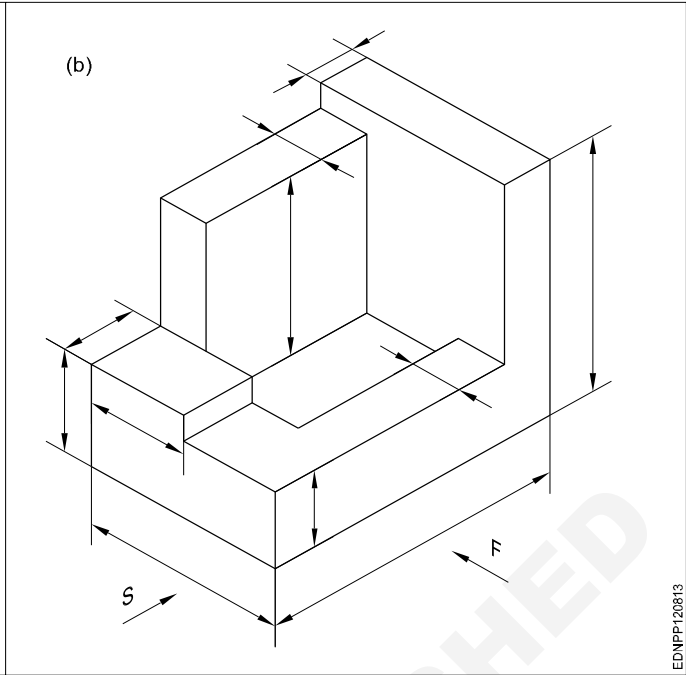
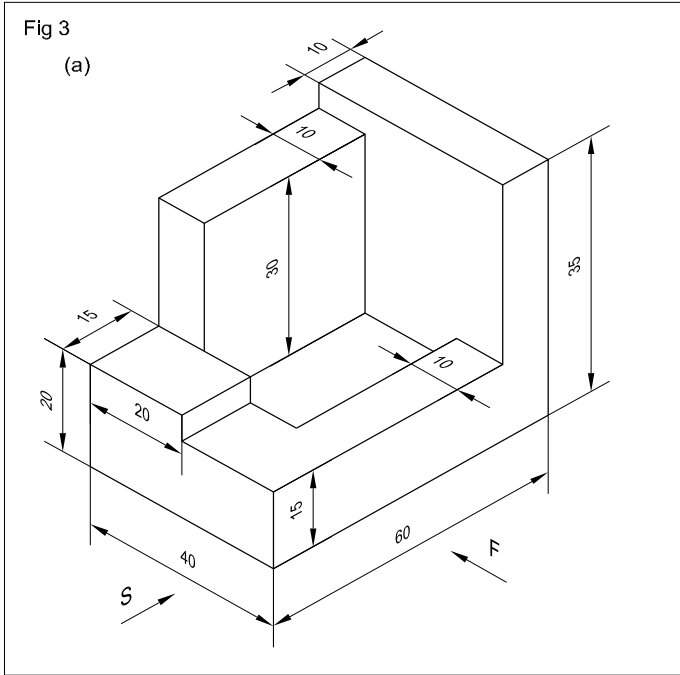

EDNPP120813

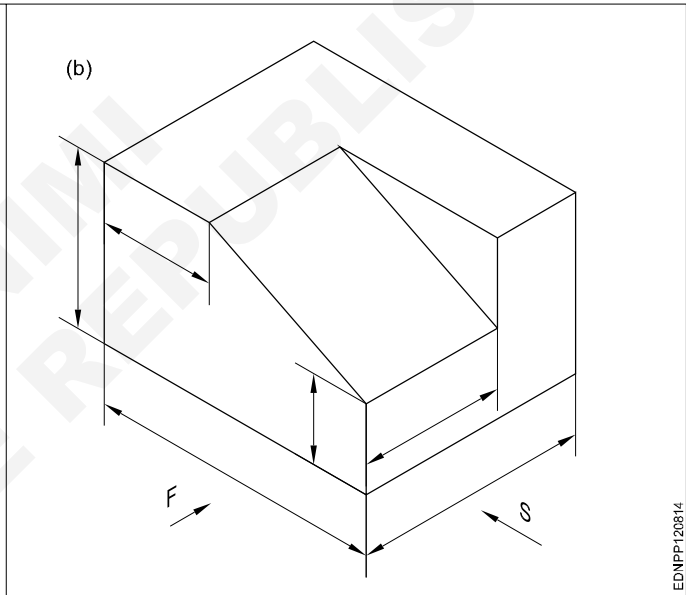
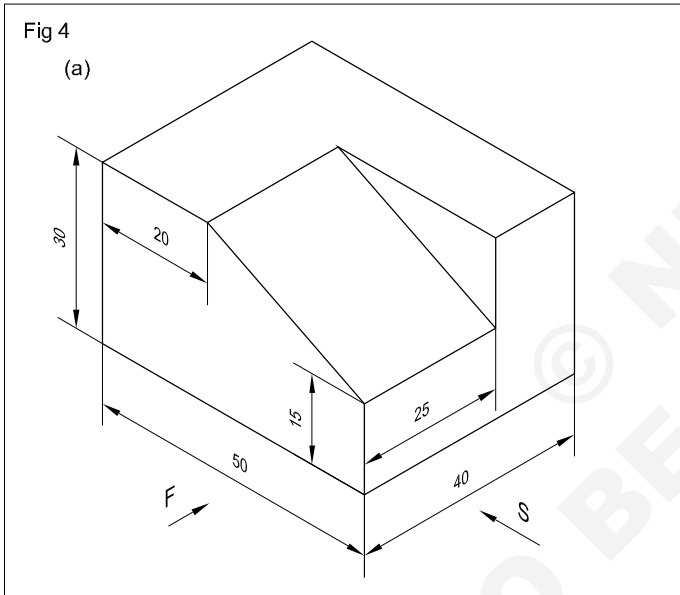

EDNPP120814

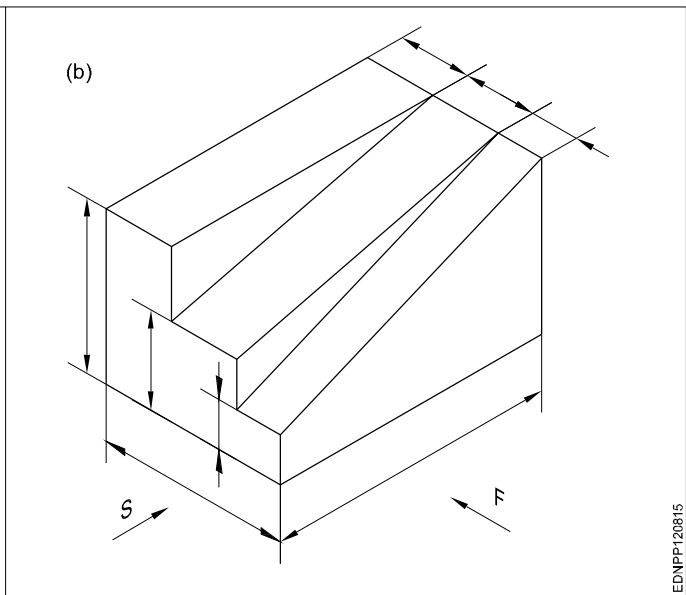
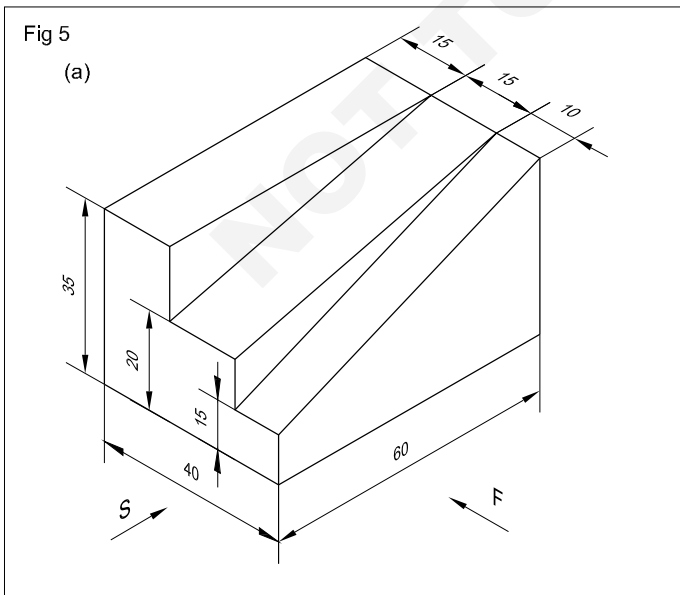

EDNPP120815

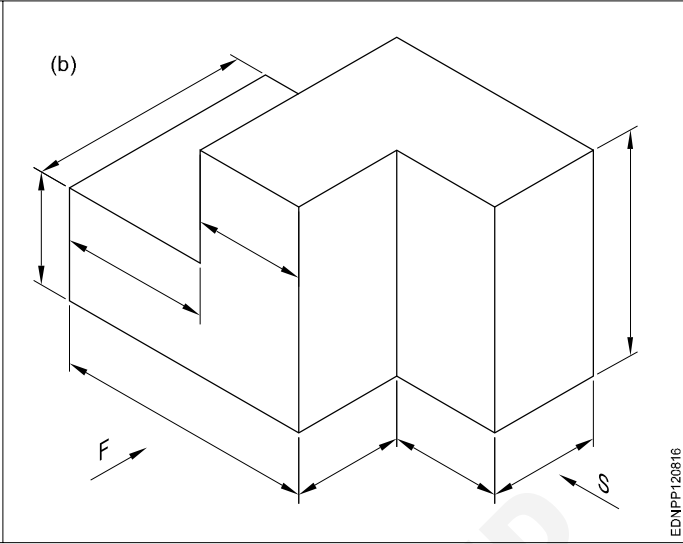
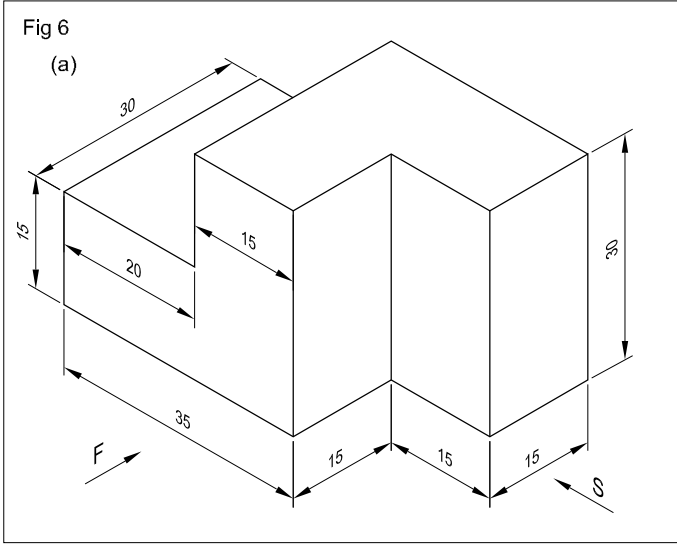

EDNPP120816

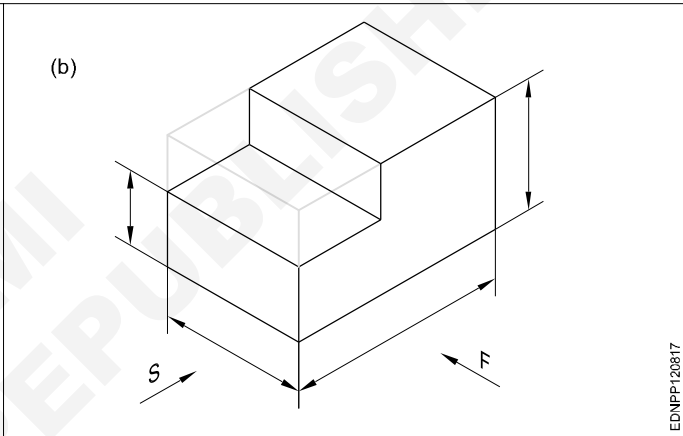
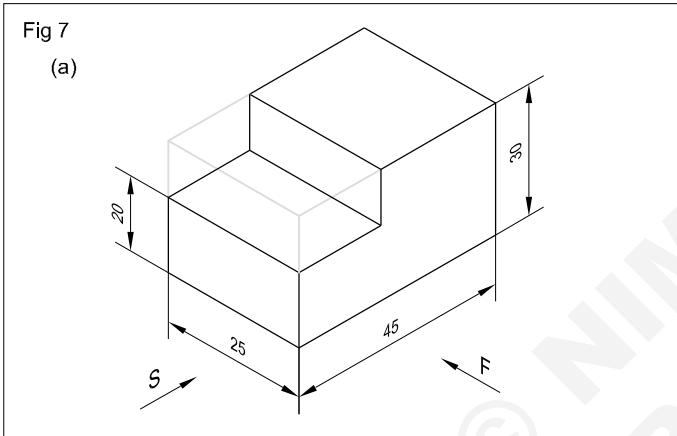

EDNPP120817

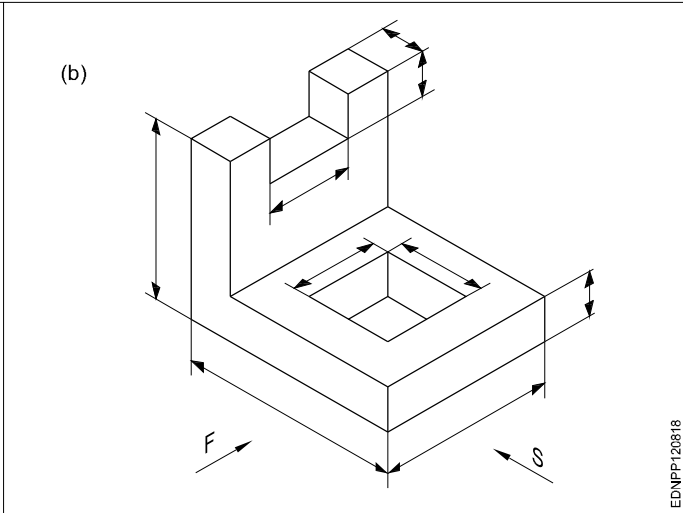
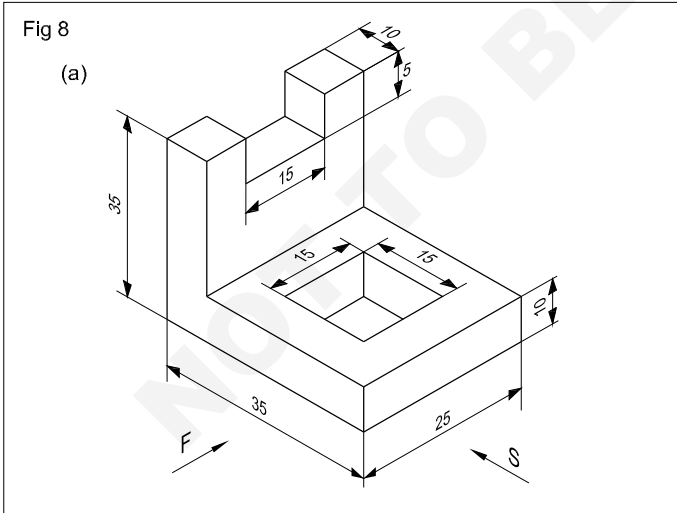

EDNPP120818

Fig 9

(a)

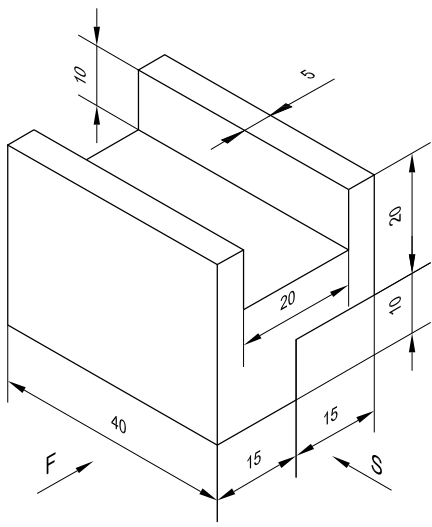

(b)

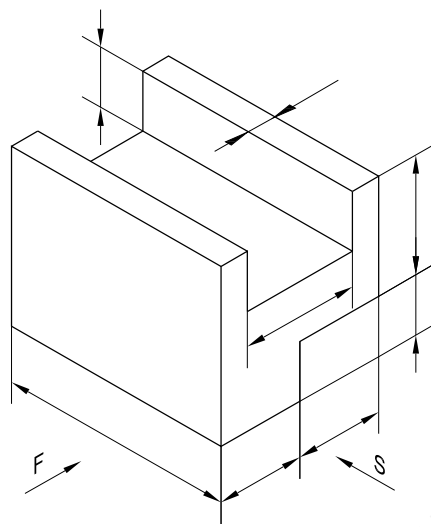

EDNPP120819

Fig 10

(a)

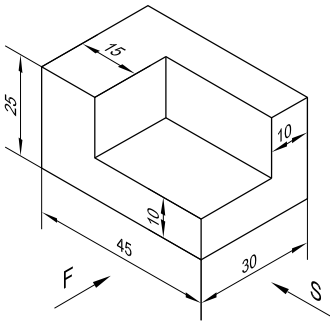

(b)

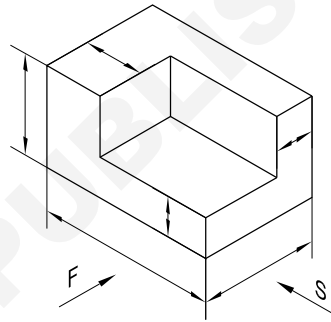

EDNPP12081A

Free hand drawing of hand tools and measuring tools

Hand Tools

Files (Fig 1)

- a Curved cut file
- b Rasp cut file
- c Single cut file
- d Double cut file

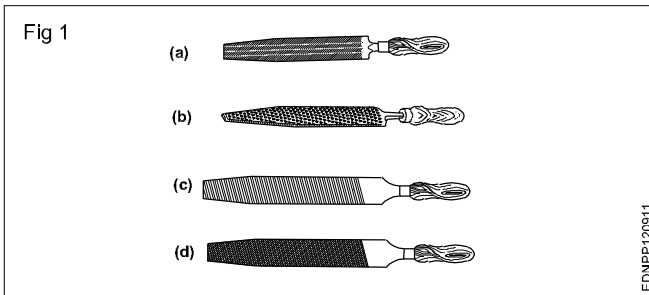

Divider (Fig 2)

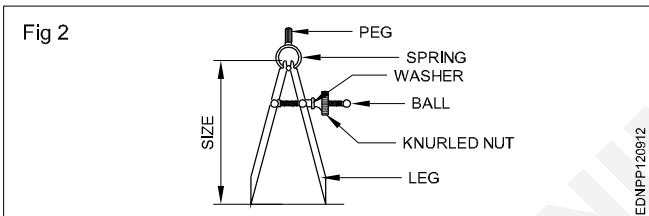

Outside caliper (Fig 3)

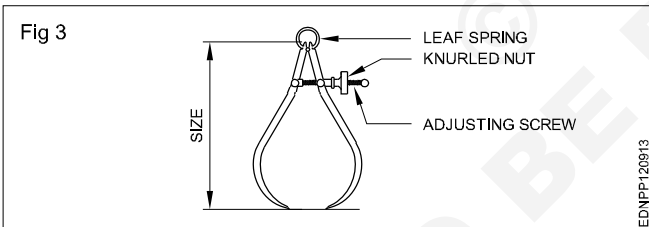

Inside caliper (Fig 4)

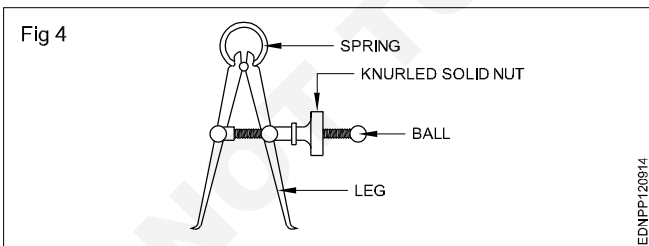

Hacksaw (Fig 5)

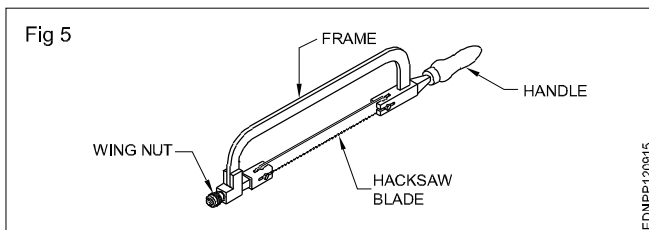

Ball peen hammer (Fig 6)

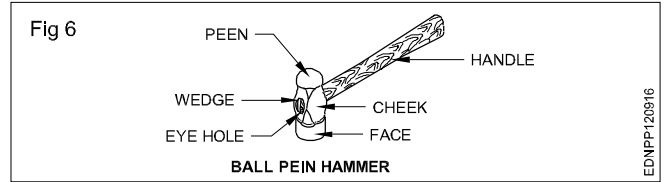

Screw driver (Fig 7)

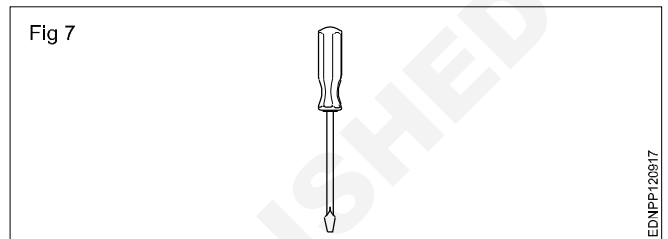

Bench vice (Fig 8)

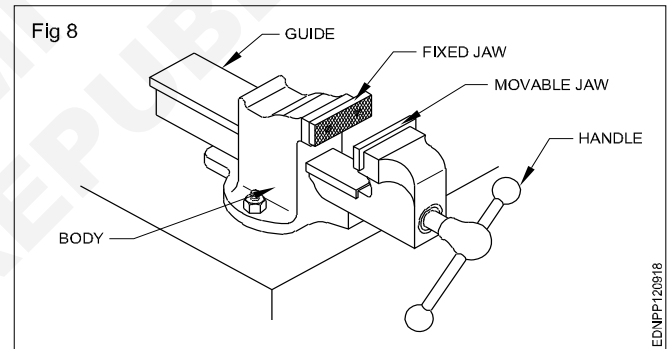

Centre punch (Fig 9)

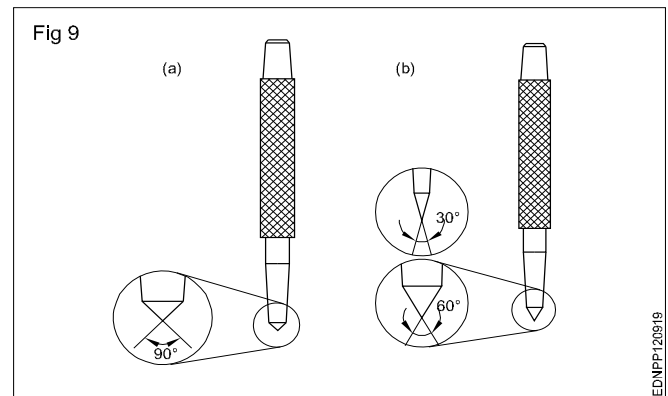

Cutting plier (Fig 10)

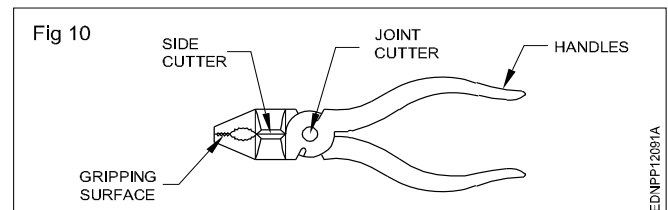

EDNPP120916

EDNPP120917

EDNPP120912

EDNPP120918

EDNPP120913

EDNPP120914

EDNPP120919

EDNPP120915

EDNPP12091A

Open-end spanner (Fig 11)

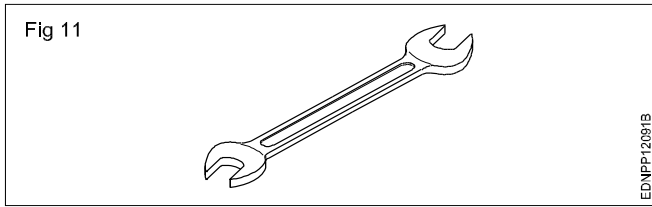

Hammers (Fig 12)

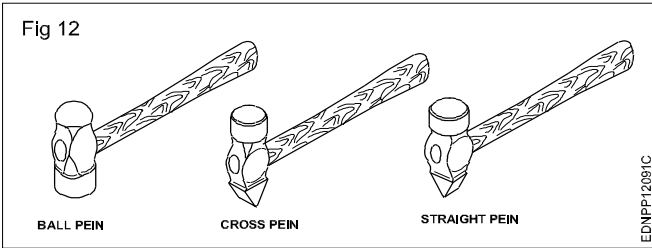

Measuring Tools

Steel rule (Fig 13)

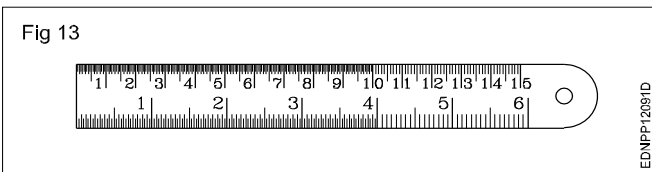

Try square (Fig 14)

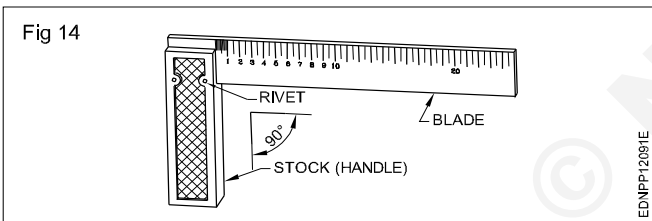

Vernier caliper (Fig 15)

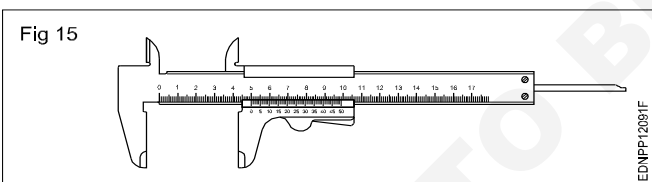

Micrometer (Fig 16)

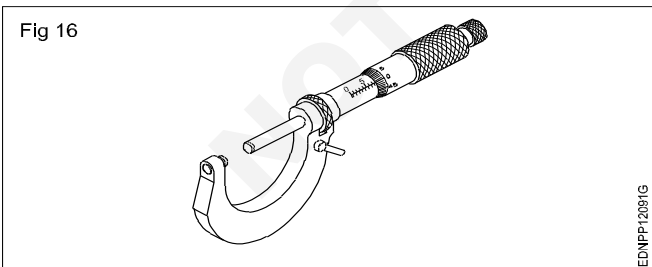

Vernier height gauge (Fig 17)

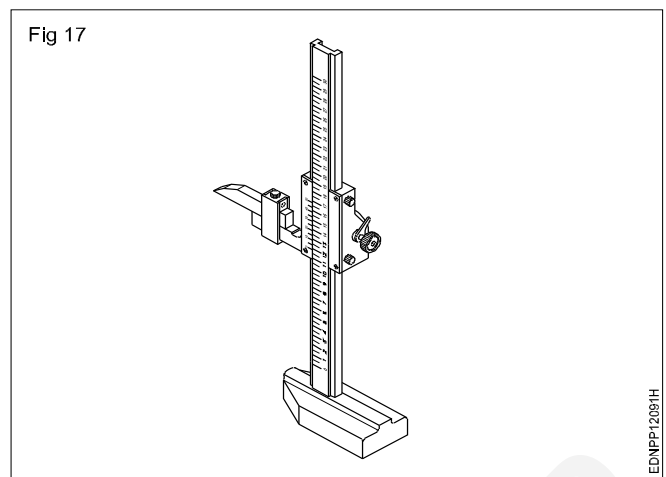

Bevel protractor (Fig 18)

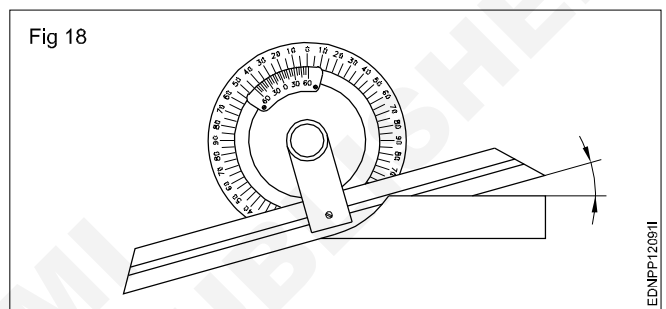

Hand Tools

Screwdriver (Fig 19)

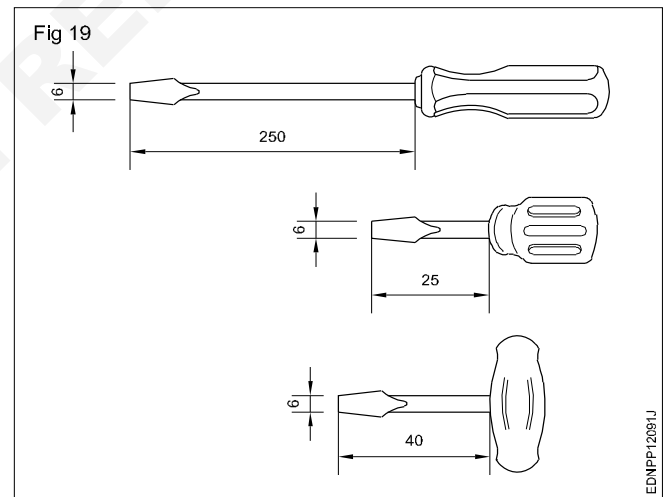

Mallet (Fig 20)

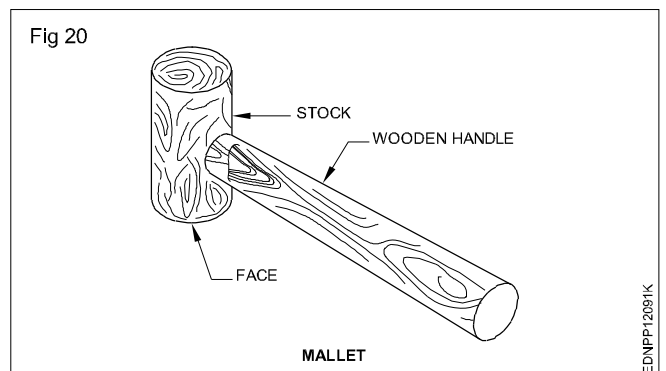

Drawing of geometrical figures - Angle & triangle

Angles: Angle is the inclination between two straight lines meeting at a point or meeting when extended. AB and BC are two straight lines meeting at B. The inclination between them is called an angle. The angle is expressed in degrees or radians.

Concept of a degree: When the circumference of a circle is divided into 360 equal parts and radial lines are drawn through these points, the inclination between the two adjacent radial lines is defined as one degree. Thus a circle is said to contain 360° . (Fig 1)

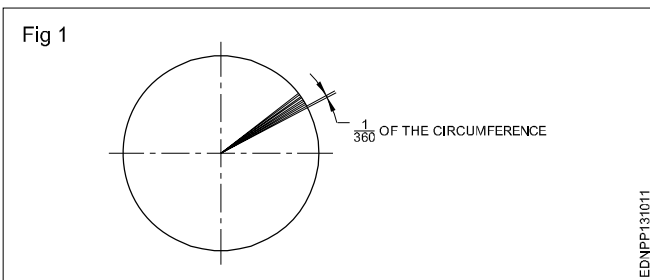

Acute angle: An angle that is less than 90° is called an acute angle. (Fig 2)

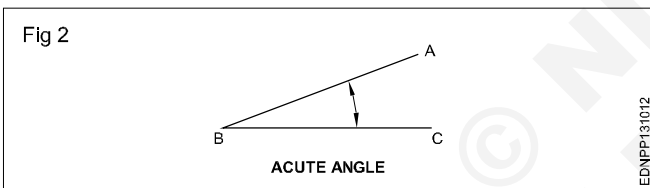

Right angle: The angle between a reference line and a perpendicular line is called a right angle. (Fig 3)

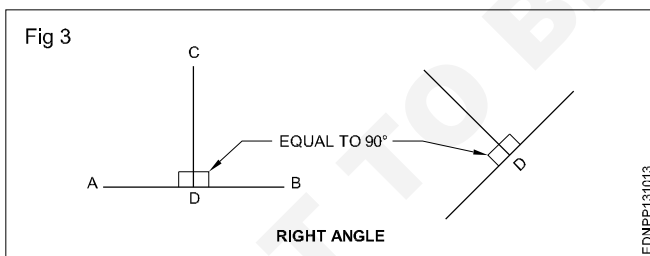

Obtuse angle: This refers to an angle between 90° and 180° . (Fig 4)

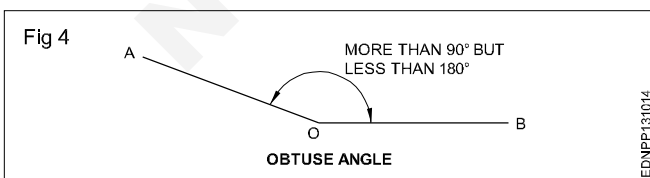

Straight angle: This refers to an angle of 180° . This is also called the angle of a straight line. (Fig 5)

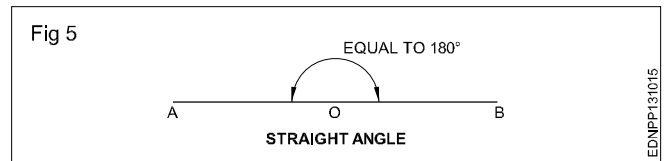

Reflex angle: It is the angle that is more than 180° , but less than 360° . (Fig 6)

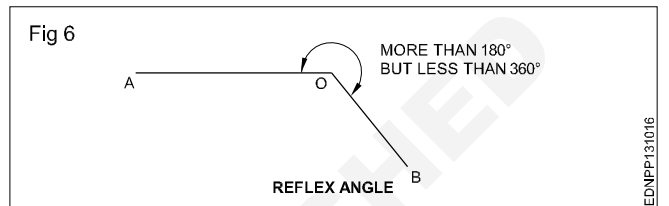

Adjacent angles: These are the angles lying on either side of a line. (Fig 7)

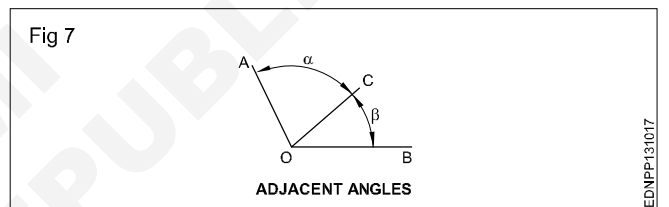

Complementary angles: When the sum of the two angles is equal to 90° , angle POQ + angle QOR = 90° angle POQ and angle QOR are complementary angles to each other. (Fig 8)

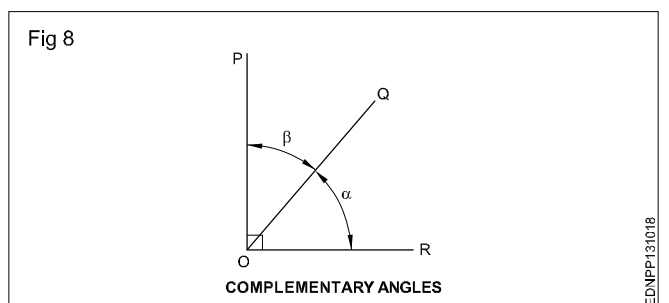

Supplementary angle: When the sum of the two adjacent angles is equal to 180° , for example, angle SOT + angle TOY = 180° , angle SOT and angle TOY are supplementary angles to each other. (Fig 9)

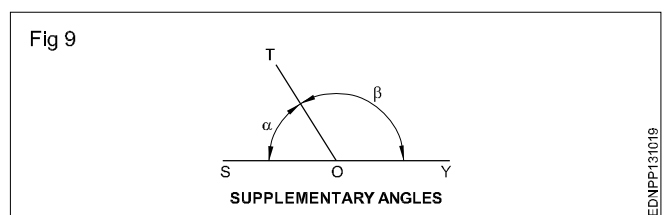

Triangle - different types

Triangle is a closed plane figure having three sides and three angles. The sum of the three angles always equals to 180° .

To define a triangle, we need to have a minimum of three measurements as follows:

- 3 sides or
- 2 sides and one angle or
- 2 angles and one side

Types of triangles

1 Equilateral triangle is a triangle having all the three sides equal. Also all the three angles are equal (60°). (Fig 1)

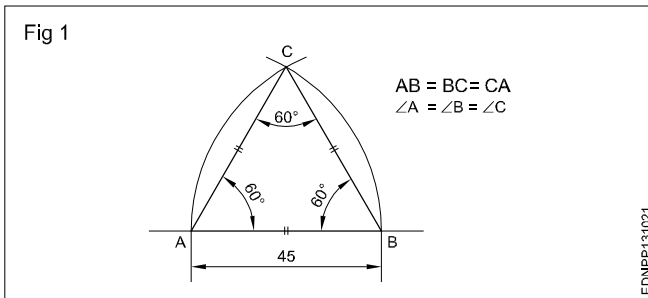

2 Isosceles triangle has two of its sides equal. The angles opposite the two equal sides are also equal. (Fig 2)

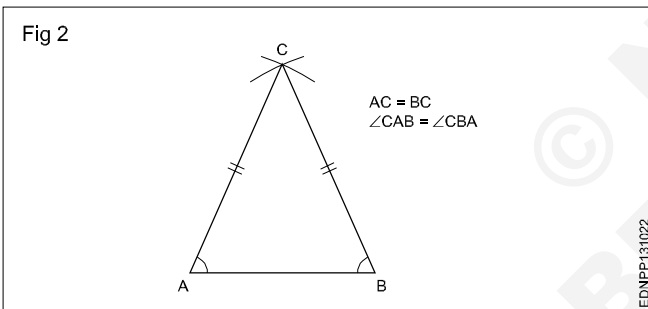

3 Scalene triangle has all three sides unequal in length. All three angles are also unequal. (Fig 3)

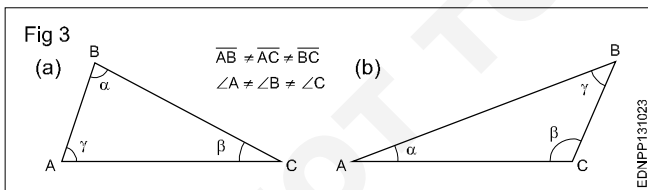

4 A right-angled triangle is one in which one of the angles is equal to 90° (Right angle). The side opposite the right angle is called the hypotenuse. (Fig 4)

5 An Acute angled triangle is one in which all the three angles are less than 90° . (Fig 5)

6 Obtuse angled triangle has one of the angles more than 90° . (Fig 6)

The sum of the three angles in any triangle is equal to 180° .

The sum of any two sides is more than the third side.

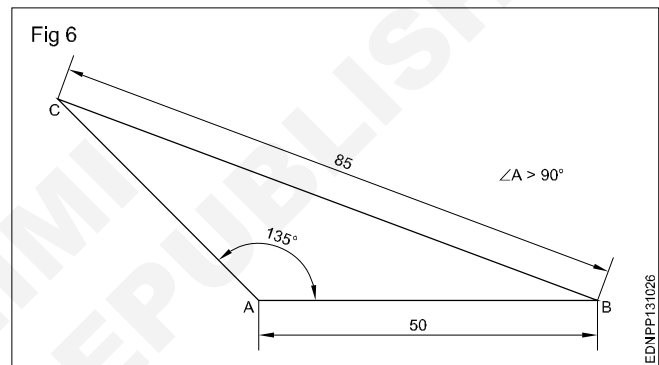
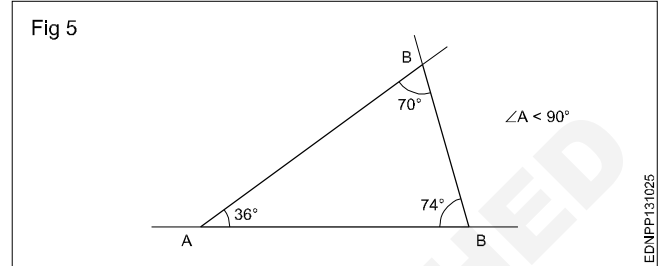
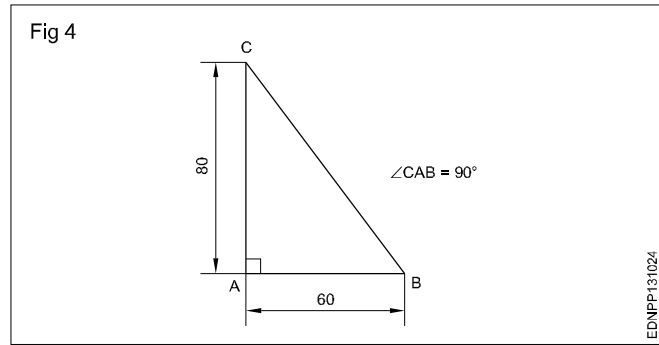

Procedure to draw the triangle

1 Equilateral triangle (Fig 1) $AB = BC = CA = 35$ mm.

- Draw a line and mark AB 35 mm side of the triangle.
- Draw radius from centre A and B, arcs cutting mark at C (Fig 1).
- Join CA and CB.
- ABC is a required triangle.

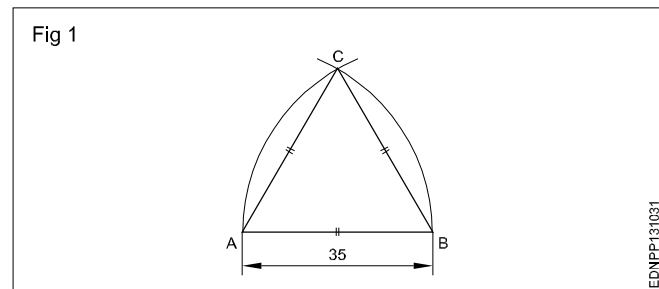

2 Isosceles triangle : $AB = AC = 60$ mm & $\angle BAC = 40^\circ$.

- Draw the side AB equal to 60 mm. 'A' as the centre, draw an arc of radius AB.
- Draw a line AC at 40° to AB.
- Join BC to form the triangle ABC. (Fig 2)

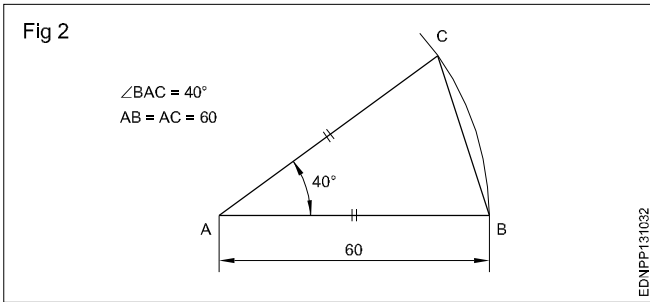

Exercise

- 1 **Scalene triangle: $AB = 30$ mm, $AC = 55$ mm & $BC = 35$ mm. (Fig 1)**

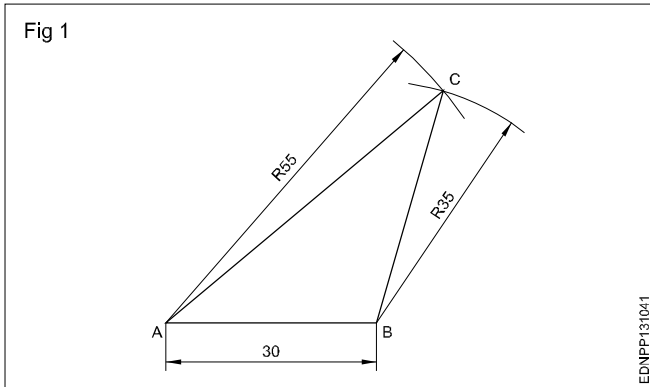

- 2 **Scalene triangle: $AB = 70$ mm. (Fig 2)**

$\angle ABC = 40^\circ$ & $\angle BAC = 110^\circ$

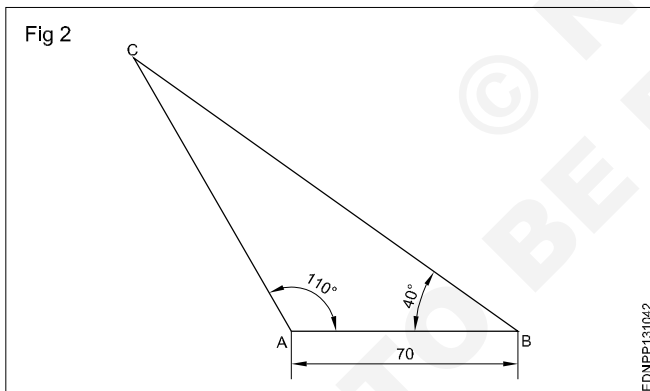

- 3 **Right angled triangle: $AB = 60$ mm, $BC = 45$ mm. (Fig 3)**

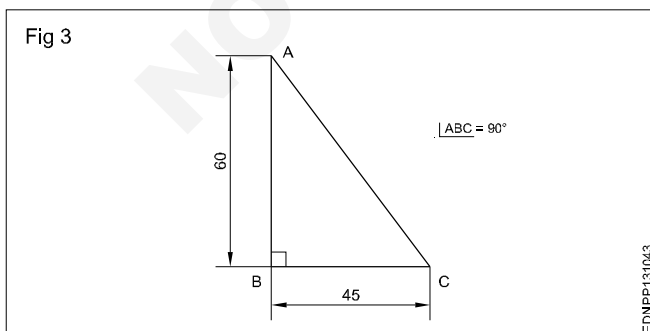

- 4 **Draw a triangle when one side and 2 angles being given in Fig 4.**

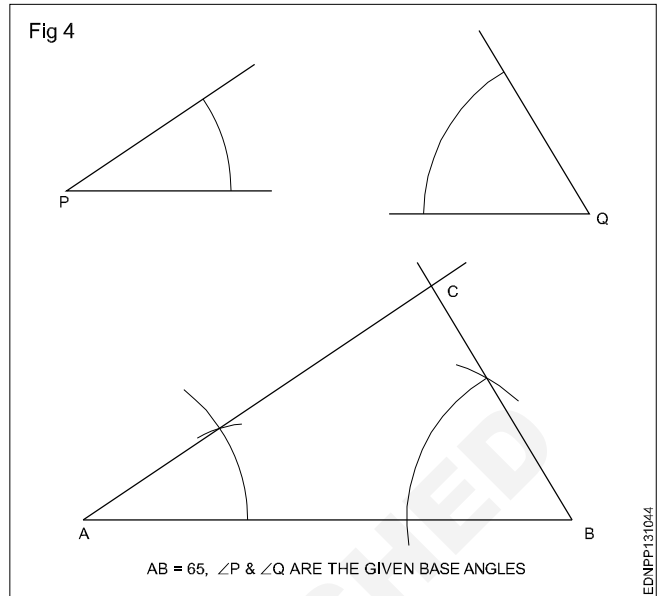

- 5 **Draw a right angled triangle when the base and hypotenuse being given in Fig 5.**

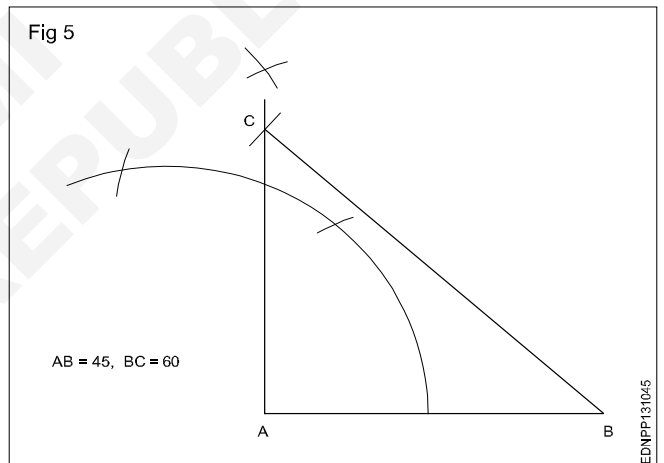

- 6 **Draw a triangle with the altitude and two sides being given in Fig 6.**

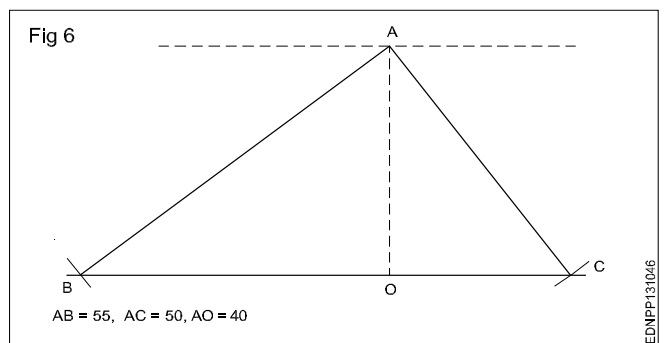

Drawing of geometrical figures - Circle

Circle: Circle is a plane figure bounded by a curve, formed by the locus of a point which moves so that it is always at a fixed distance from a stationary point the "Centre".

Radius: The distance from the centre to any point on the circle is called the "Radius".

Diameter: The length of a straight line between two points on the curve, passing through the centre is called the "Diameter". (D: Dia or d) It is twice the radius.

Circumference: It is the linear length of the entire curve, equal to πD .

Arc: A part of the circle between any two points on the circumference or periphery is called an 'Arc'.

Chord: A straight line joining the ends of an arc is called the chord. (Longest chord of the circle is the diameter)

Segment: A part of the circle or area bound by the arc and chord is the segment of the circle.

Sector: It is the part of a circle bounded by two radii (plural of radius) meeting at an angle and an arc.

Quadrant: Part of a circle with radii making 90° with each other is a quadrant (one-fourth of the circle).

Half of the circle is called a semi-circle.

Tangent: The tangent of a circle is a straight line just touching the circle at a point. It does not cut or pass through the circle when extended.

Fig 1 shows all the above elements.

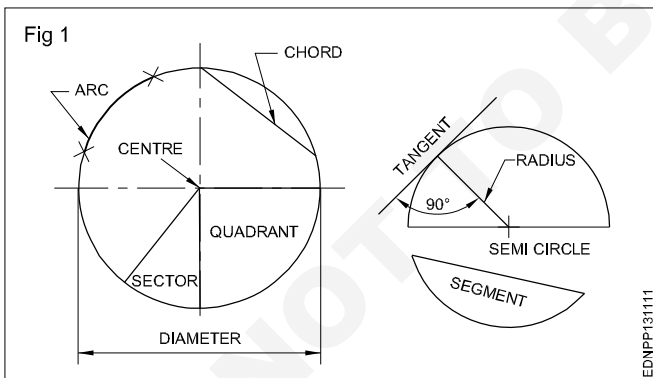

Concentric circles: When two or more circles (drawn) have a common centre, they are called concentric circles. Ball-bearing is the best example of concentric circles. (Fig 2)

Eccentric circles: Circles within a circle but with different centres are called eccentric circles. (Fig 3)

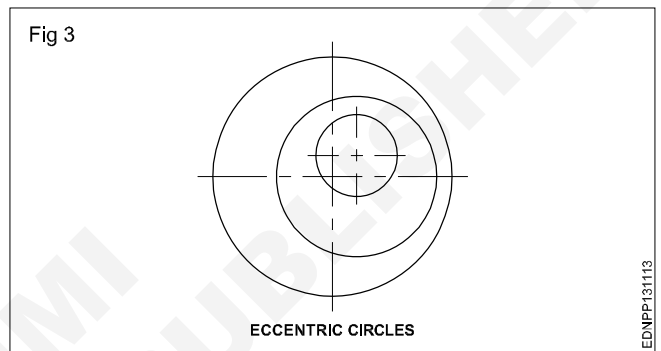
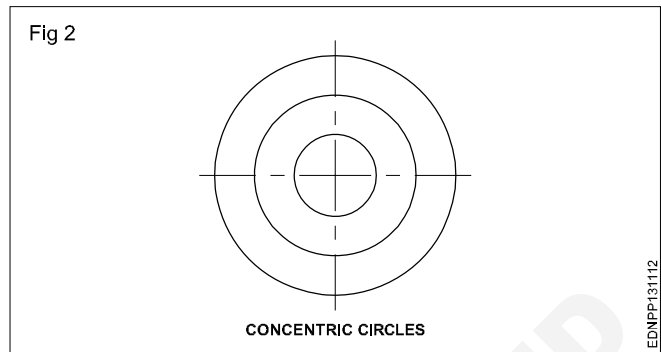

Circle and Arcs

Exercise

1 Draw a tangent to a given circle of ϕ 50 mm at any point 'P' on it. (Fig 1)

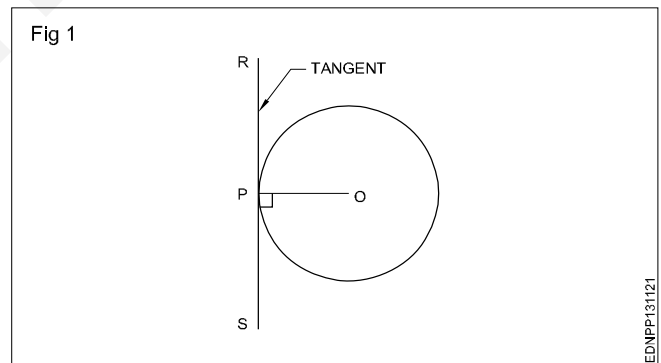

2 Draw a loop of 3 circles pattern. (Fig 2)

Draw any line MN and mark points A, B and C. So that AB = 20 mm and BC = 25 mm.

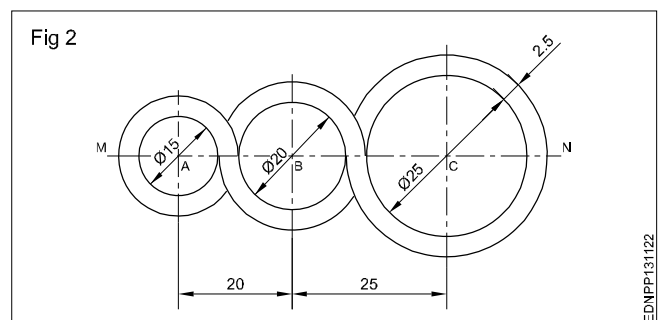

Drawing of geometrical figures - Square, rectangle and parallelogram

A quadrilateral is a plane figure bounded by four sides and four angles. The sum of the four angles in a quadrilateral is (interior angles) equal to 360° . The side joining opposite corners is called diagonal. To construct a quadrilateral out of four sides, four angles and two diagonals a minimum of five dimensions are required of which two must be sides. Quadrilaterals are also referred as Trapezium. (Fig 1)

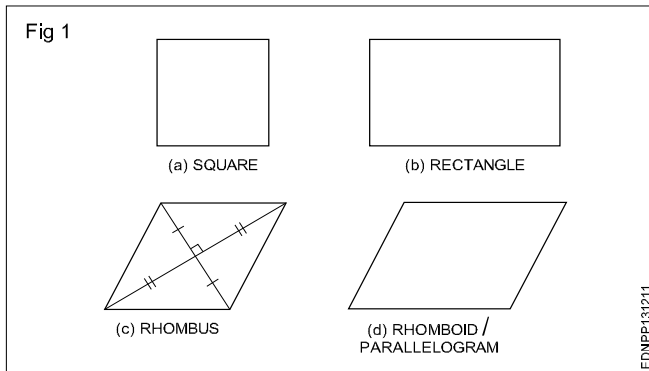

Types of quadrilaterals (Fig 1)

- Square
- Rectangle
- Rhomboid / Parallelogram

Square: In a square all the four sides are equal and its four angles are at right angles. The two diagonals are equal and perpendicular to each other.

Rectangle (Fig 2): In a rectangle, opposite sides are equal and parallel and all four angles are right angles.

Fig 2 shows a rectangle ABCD, Sides $AB = DC$ and $BC = AD$. Diagonals AC and BD are equal. Diagonals are not bisected at right angles.

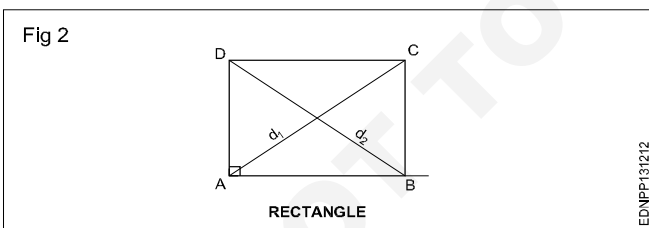

Rhomboid/Parallelogram (Fig 3): In a parallelogram, opposite sides are equal and parallel. Opposite angles are also equal. Diagonals are not equal but bisect each other.

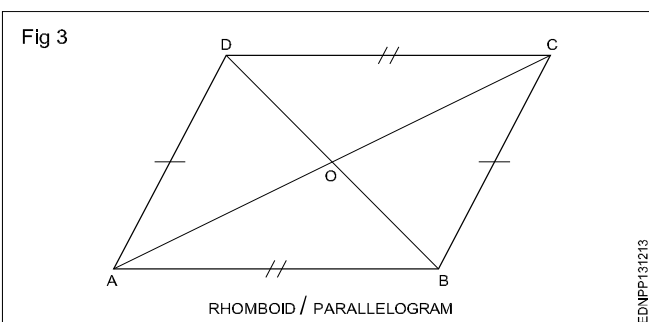

Procedure to draw the square, rectangle and parallelogram

Square

1 **1st method (Fig 1):** A square of side 50 mm by erecting perpendicular using compass and 45° set square.

Draw a line 50mm. 'A' as centre draw an arc of convenient radius. Same arc cut and mark as PQR. Draw a line perpendicular, mark 50mm and make a square as shown in figure.

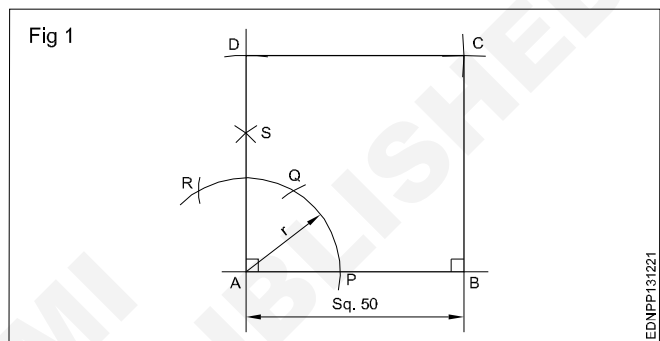

2 **2nd method (Fig 2):** A square of side 60 mm using 45° set square and compass.

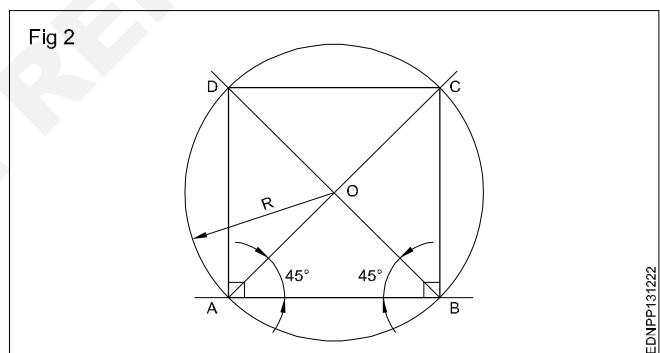

Draw a horizontal line $AB = 60$ mm. From point 'A' & 'B' using 45° set square draw diagonal and circle of radius OA with centre 'O'. Join points AD, DC & CB to complete the required square.

3 **3rd method (Fig 3):** A square of side 60 mm long by erecting perpendicular and also using 45° set square. Mark AD, BC and join ABCD to get the required square.

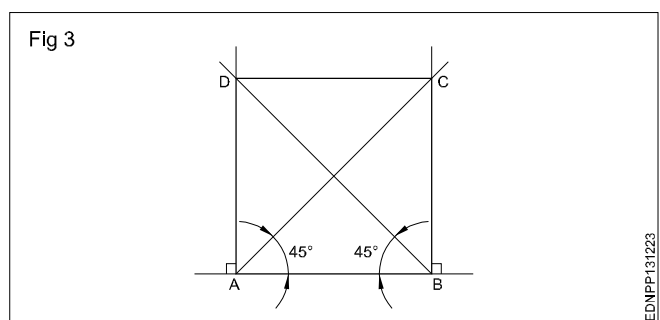

4 Square having diagonal 60 mm (Fig 4)

Draw horizontal and vertical centre lines intersect at 'O' and make a circle. Join all the points ABC&D to get the required square.

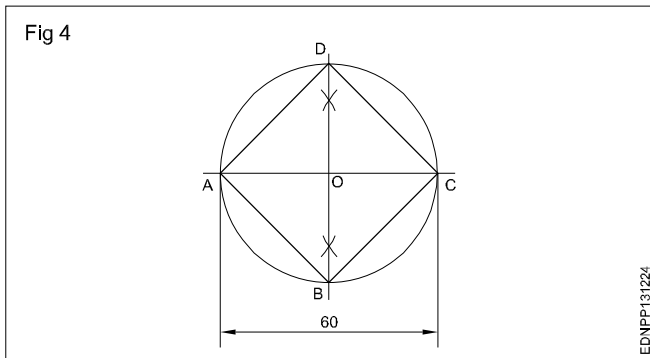

5 Rectangle (Fig 5)

Draw AB = 75 mm and side AD = 45 mm using setsquare and compass. Draw BC = 45 mm using setsquare and compass. Join ABCD to get the required rectangle.

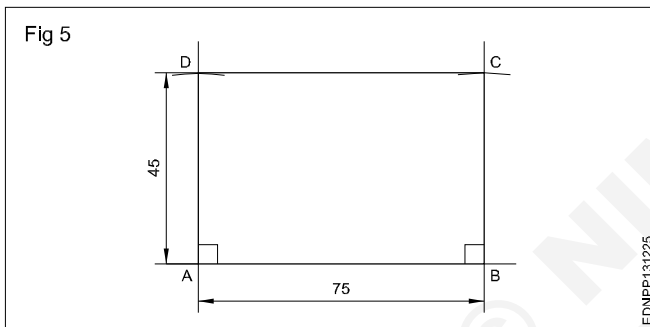

6 Rectangle - Diagonal - 60 mm and one side 20 mm 1st method (Fig 6a)

2nd method (Fig 6b)

ADBC is the required rectangle of side 20 mm and diagonal 60 mm by using setsquare and compass.

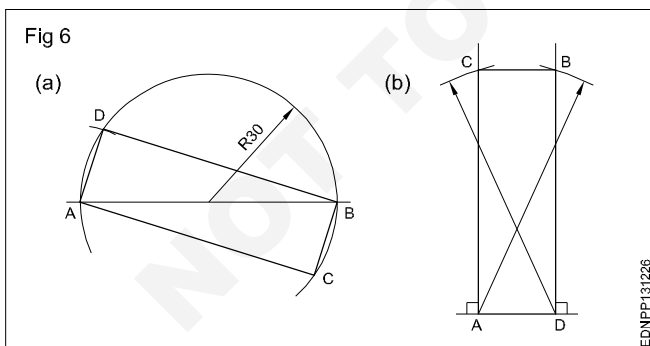

7 Parallelogram (Fig 7)

Sides = 75 mm and 40 mm, angle 50°

- Draw line AD equal to 40 mm and 50° angle to AB.
- 'D' as centre, draw an arc of radius equal to AB.
- 'B' as centre, draw an arc of radius equal to AD, upwards such that they meet at a point 'C'. Join ABCD to get the required parallelogram.

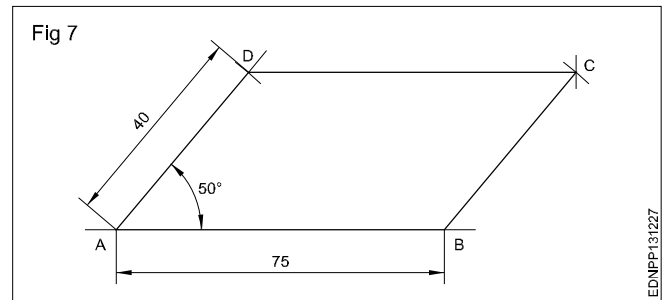

8 Parallelogram (Fig 8)

Parallelogram - Side AB = 60 mm

Diagonal AC = 90 mm $\angle ABC = 120^\circ$

- Draw a line AB = 60 mm. Draw a line from B to an angle 120° to AB.
- 'A' as centre with radius 90 mm, draw an arc cutting 120° line from 'B' at 'C'.
- 'C' as centre, radius = AB, draw an arc.
- 'A' as centre and BC as radius, draw another arc, both arcs meet at 'D'. Join AD and DC.

ABCD is the required parallelogram.

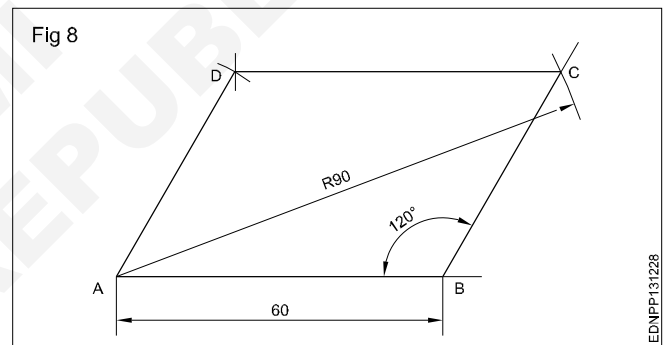

9 Parallelogram (Fig 9)

Sides AB = 55 mm, BC = 40 mm and vertical height = 30 mm.

- Draw the line AB = 55 mm long.
- 'A' and 'B' as centres and radius (R) 30 mm, draw arcs above the line.
- Draw a parallel tangential line to AB touching the arcs.
- 'A' and 'B' as centres, draw an arc of 40 mm radius cutting the line at 'D' and 'C'.

ABCD is the required parallelogram.

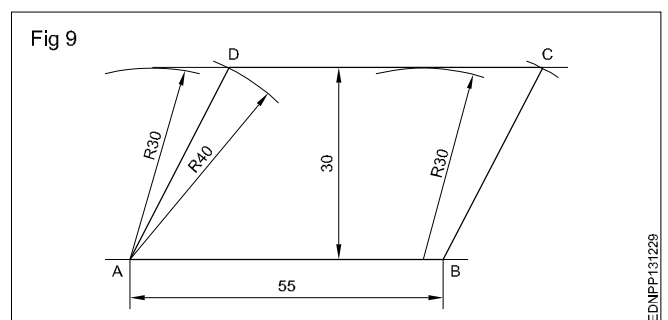

Lettering and numbering - Single stroke

Styles of lettering: Many styles of lettering are in use today. However, a few styles which are commonly used are shown in Fig 1.

Fig 1

ABCDEFGH abcdefgh	GOTHIC ALL LETTERS HAVING THE ELEMENTARY STROKES OF EVEN WIDTH ARE CLASSIFIED AS GOTHIC
ABCDEF GH abcde fgh	ROMAN ALL LETTERS HAVING THE ELEMENTARY STROKES "ACCENTED" OR CONSISTING OF HEAVY AND LIGHT LINES ARE CLASSIFIED AS ROMAN
<i>ABCDEF GH</i> <i>abcde fgh</i>	ITALIC ALL SLANTING LETTERS ARE CLASSIFIED AS ITALIC. THESE MAY BE FURTHER DESIGNATED AS ROMAN-ITALICS, GOTHIC-ITALICS, TEXT-ITALICS
A B C D E F G H a b c d e f g h	TEXT THIS TERM INCLUDES ALL STYLES OF OLD ENGLISH, GERMAN TEXT. BRADLEY TEXT OF OTHERS OF VARIOUS TRADE NAMES. TEXT STYLES ARE TOO ILLEGIBLE FOR COMMERCIAL PURPOSES

EDNPP131311

Standard heights/Width: The standard heights recommended by BIS SP: 46-2003 are in the progressive ratio of "square root 2". They are namely 2.5 - 3.5 - 5 - 7 - 10 - 14 and 20 mm. The height of lower case letter (without tail or stem) are 2.5, 3.5, 5, 7, 10 and 14 mm.

There are two standard ratios for the line thickness "d". They are A & B. In A = line thickness (d) is h/14 and in B=line thickness (d) is h/10.

Lowercase means small letters, as opposed to capital letters. The word yes, is for example, is in **lowercase**, while the word YES is in **upper case**. For many programmes, this distinction is very important. Programmes that distinguish between **uppercase** and **lowercase** are said to be case sensitive

The width of different letters in terms of "d" is as follows:

Lettering A

Width (W)	Capital letters	Width
1	I	1d
5	J,L	5d
6	C,E,F	6d
7	B,D,G,H,K,N,O,P,R,S,T,U & Z	7d
8	A,Q,V,X,Y	8d
9	M	9d
12	W	12d

Lower case letters and numerals

Width (W)	Letters/Numerals	Width
1	i	1d
3	j,l	3d
4	f,t,l	4d
5	c,r	5d
6	a,b,d,e,g,h,k,n,o,p,q,s,u,v;3;5	6d
7	a,0 (zero), 2,4,6,7,0,8,9	7d
9	m	9d
10	w	10d

The width of different letters in terms of stroke (line) is as follows:

Uppercase Lettering BIS SP: 46-2003

Width (W)	Capital letters
1	I
4	J
5	C,E,F,L
6	B,D,G,H,K,N,O,P,R,S,T,U & Z
7	A,M,Q,V,X,Y
9	W

Lower case letters and numerals

Width (W)	Letters/Numerals
1	i
2	l
3	j,l
4	c,f,r,t
5	a,b,d,e,g,h,k,n,o,,q,s,u,v,x,y,x 0,2,3,5 to 9
6	0,2,3,5 to 9 a,4

Spacing of letters: Recommended spacing between characters, a minimum spacing of baselines and minimum spacing between words as per BIS SP: 46-2003 are given below in Fig 2.

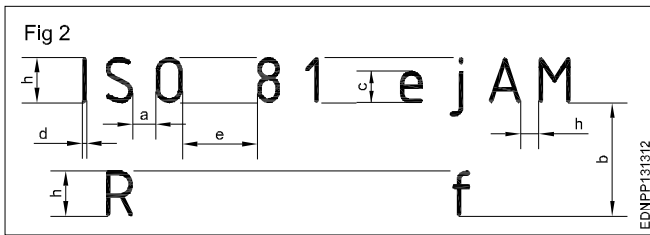

Lettering

Procedure

- 1 Print 10 mm single stroke capital letters and numerals in vertical style using either scale or set-square and by freehand. (Fig 1)

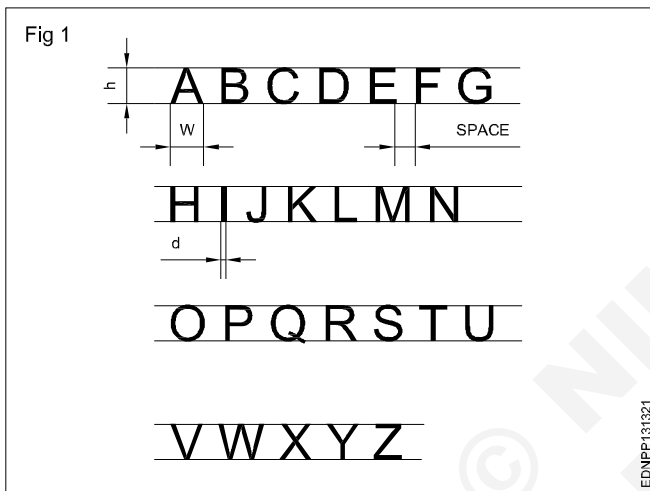

- Draw horizontal parallel lines (thin lines) of 10 mm distance.

10 mm distances denote the height of the letter.

- Mark the width of the letters recommended by BIS (IS:9609-1983)

The width of different letters in terms of 'd' is as follows: 'd' indicates stroke thickness i.e d: h/ 10.

Width (W)	Capital letters
1	I
4	J
5	C, E, F, L
6	B, D, G, H, K, N, O, P, R, S, T, U & Z
7	A, M, Q, V, X, Y
9	W

For curved letters use a smooth freehand curve.
Print straight line letters using either scale or set-squares.
To maintain the uniform thickness of the line, use a conical point soft grade pencil and avoid too much sharpness.
Guidelines of both top and bottom should always be drawn with a sharp pencil.

Numerals 2.1 (Fig 2)

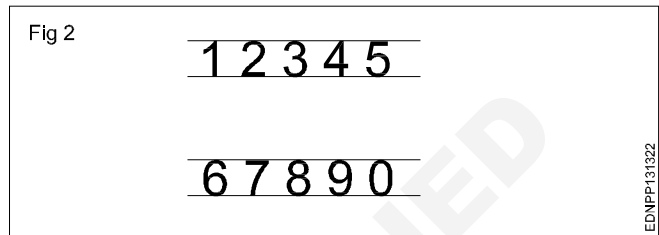

- Follow the same procedure of letters.
- 'h' is height of numerals and 'd' is the stroke thickness.
- Width of numerals in terms of 'd' is as follows shown in square grid (Fig 3).

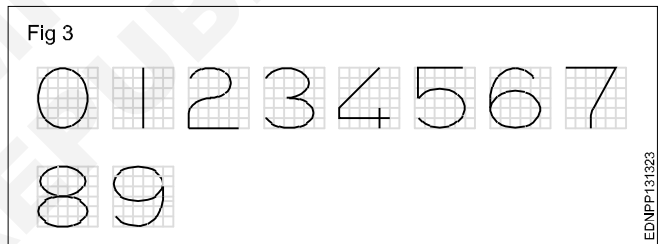

- 2 Print 10 mm single stroke capital letters and numerals in inclined style (Fig 4).

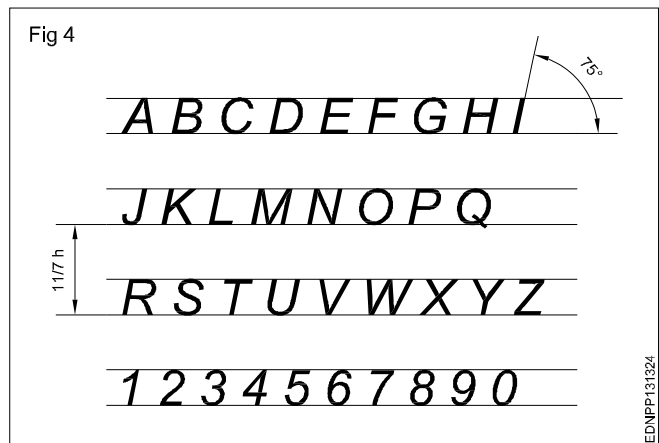

Practice the following lettering exercises in A3/A4 paper as per the given ratio

1 Single stroke inclined letters of ratio 7:6, 7:5, 7:4, 7:3, 7:1 (Fig 5)

Fig 5



SINGLE STROKE INCLINED LETTERS

EDNPP131325

2 Single stroke vertical letters of ratio 7:6, 7:5, 7.4, 7:3, 7:1 (Fig 6)

Fig 6

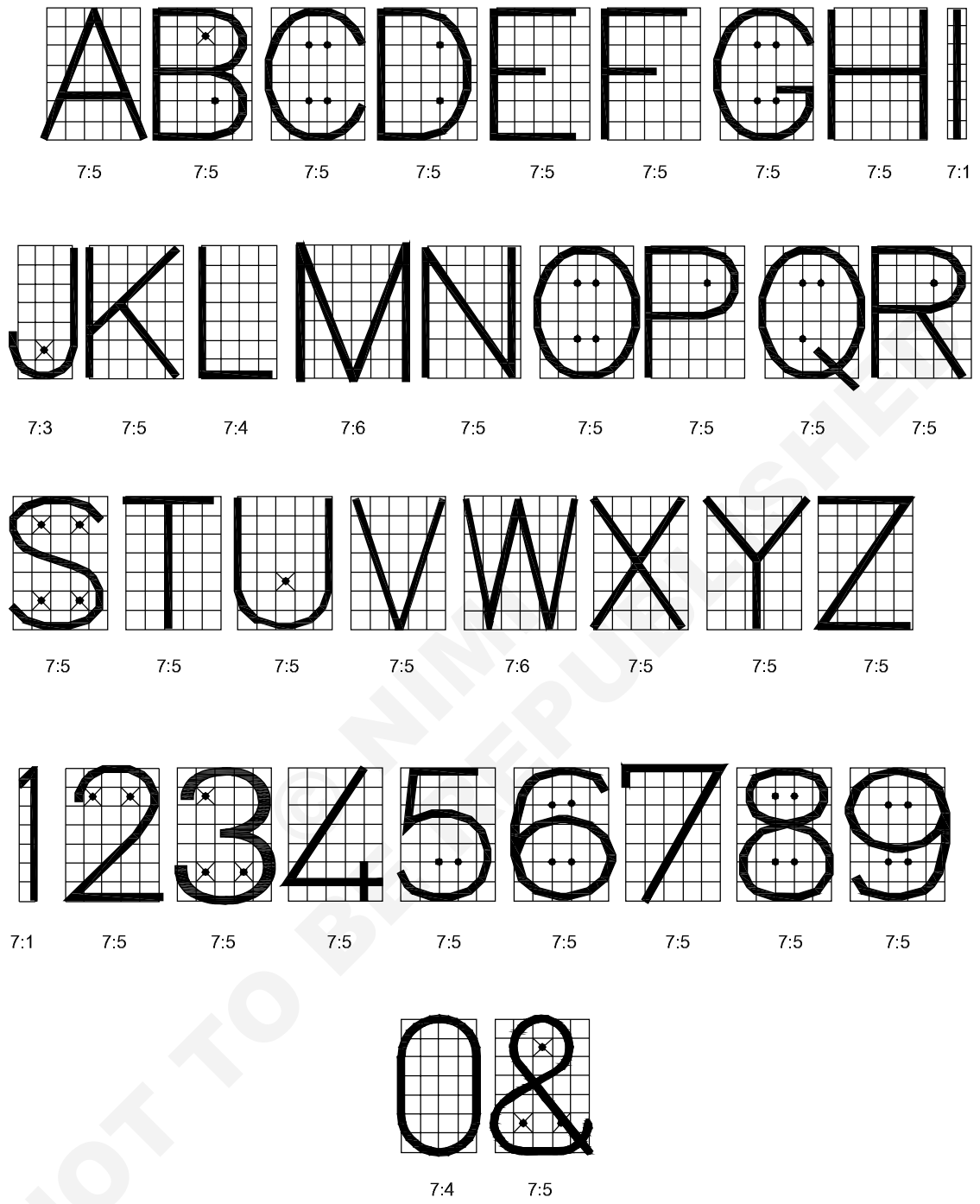

SINGLE STROKE VERTICAL LETTERS

EDNPP-131326

Dimensioning - Types of arrow heads and leader line with text

Dimension line: These are thin continuous lines, terminated at ends by arrowheads, dots or oblique lines touching the extension line. (Fig 1)

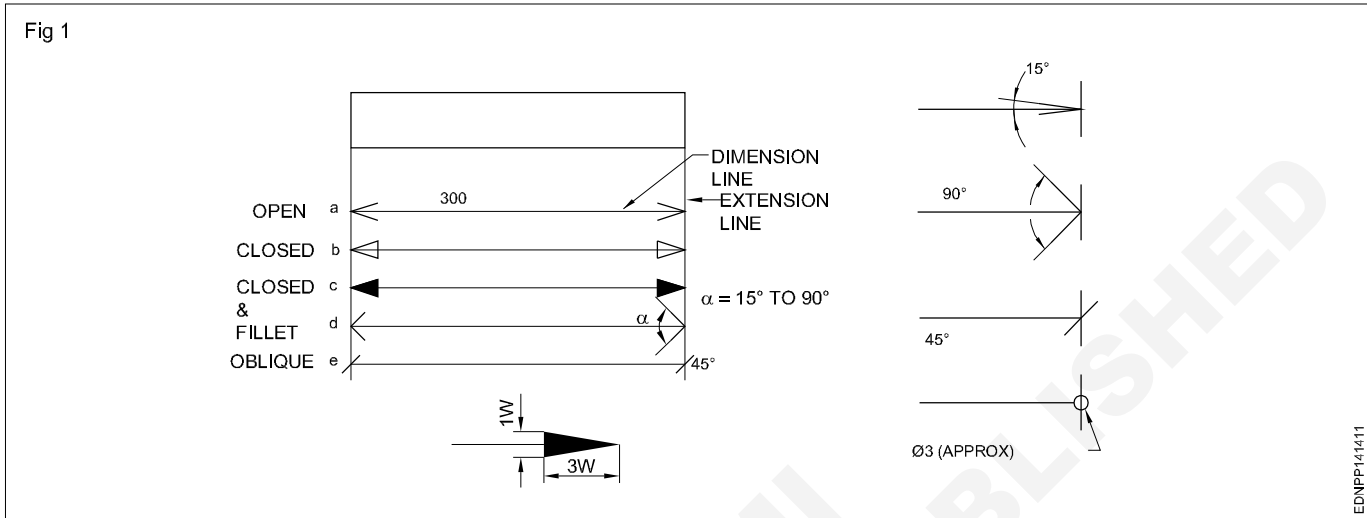

A dimension line may cut or cross another dimension line where there is no other way.

Dimension to the hidden lines be avoided. (Fig 2)

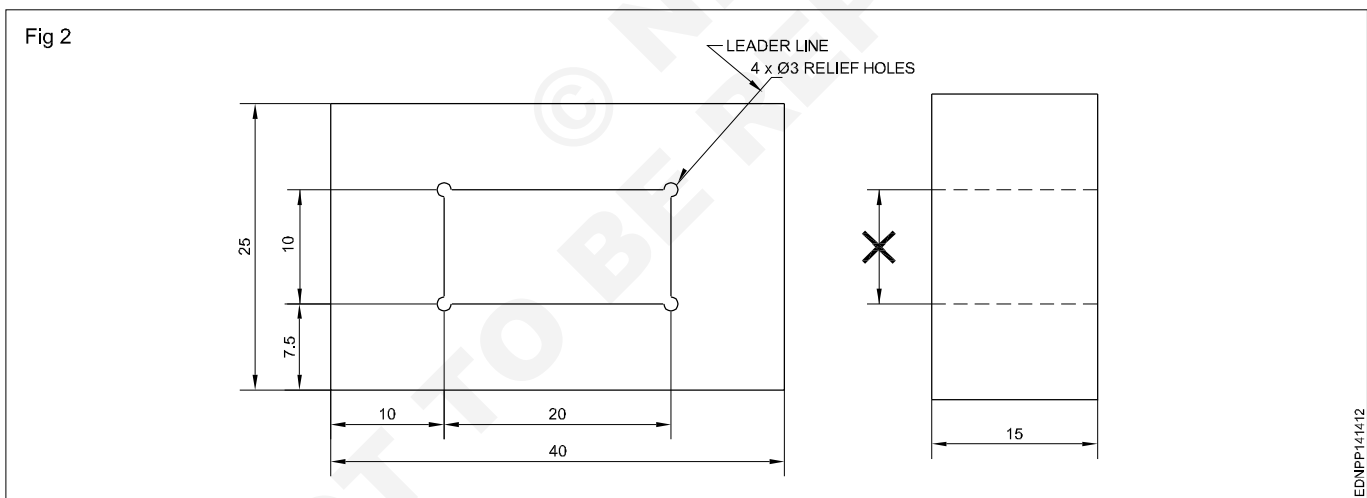

Arrowheads may be placed outside where space is insufficient.

Leader line: It is a thin continuous line. It connects a note or dimension with the features to which it applies. (Fig 2)

Termination and Origin indication: The size of the terminations (arrowheads/oblique strokes) shall be proportional to the size of the drawing. Only one style of arrowhead shall be used on a single drawing. However, where the space is too small for the arrowheads, it may be substituted by a dot or by an oblique line. Arrowheads are drawn as short lines forming barbs at any convenient

included angle between 15° and 90° . They may be open, closed or closed and filled in. Oblique strokes are drawn as short lines inclined at 45° . (Fig 1)

Indicating dimensional values on drawings: All dimensional values shall be shown on drawings in characters of sufficient size to ensure complete legibility on the original drawings as well as on reproductions made from micro-filming.

They shall be placed in such a way that they are not crossed or separated by any other line on the drawing.

Dimensioning - Position of dimensioning (aligned, unidirectional)

Definitions related to dimensioning

Dimension: It is a numerical value expressed as an appropriate unit of measurement and indicated graphically on technical drawings with lines, symbols and notes.

Dimensions are classified according to the following types:

Functional dimension (F): It is a dimension that is essential to the function of the component or space. They are generally shown with limits. (Fig 1)

Non-functional dimension (NF): It is a dimension that is not essential for the function of the component or space.

Auxiliary or Reference dimension (AUX/REF): It is the dimension given for information only. It is derived from the values given on the drawing or related documents and it will not be given for production or inspection. (Fig 1)

Location dimension: Gives or fixes the relationship of the features. viz centre of holes, slots and any significant forms. (Fig 2)

eg: L4, L5, L6

Feature: It is an individual characteristic such as a flat surface, cylindrical surface, shoulder, screw thread, a slot, a curve or profile etc. (Fig 3 & 4)

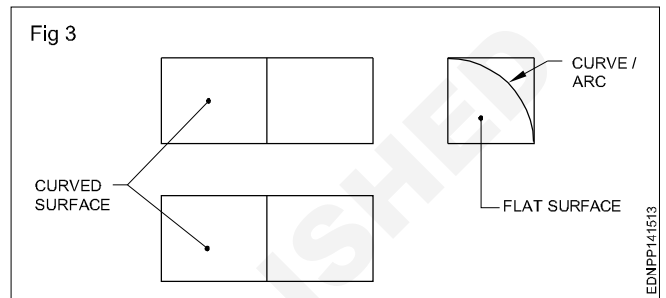

End product: It is a part ready for direct use or assembly or it can be a part ready for further process. e.g. a casting, shoulder screw etc. (Fig 4)

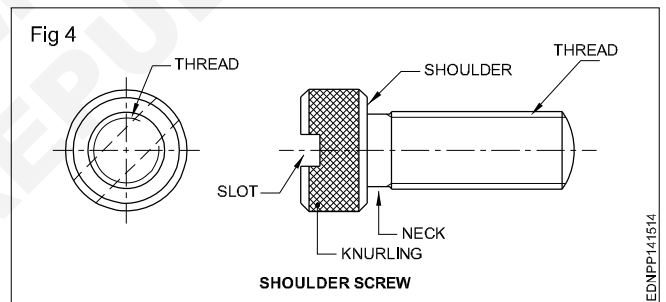
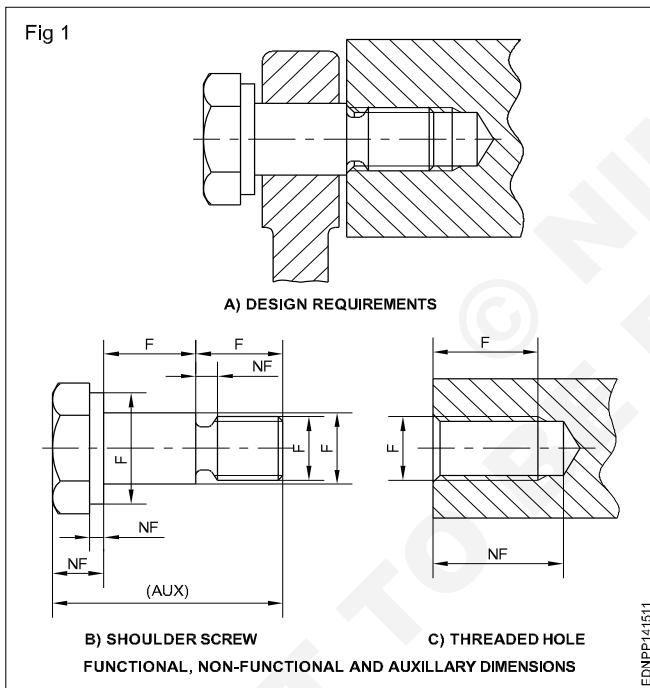

The unit of measurement in general, unless otherwise specified in mm (millimetres). On the dimensions of drawings the abbreviation mm is omitted and a general note is given in an appropriate corner as "All dimensions are in mm".

Size dimensions: Gives the size of a component, part, hole, slot, depth, width, radius etc.

eg: L1, L3, H, h1, S etc. (Fig 2)

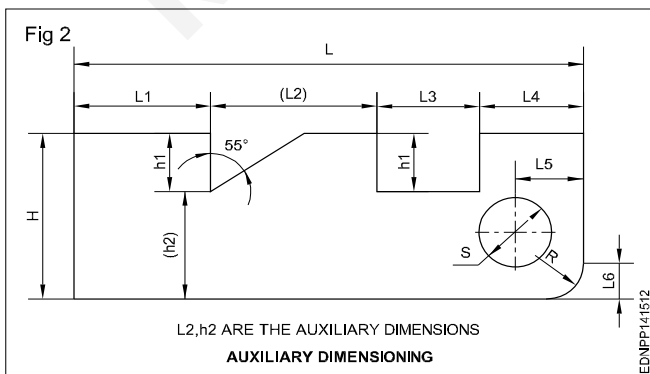

Elements of dimensioning

- Extension line - a
- Dimension line - b
- Leader line - c
- Termination of dimension line - d
- The original (starting point) indication and the dimension (a).

Extension line: It is a thin line projecting from the feature and extending beyond the dimension line. (Fig 5)

It is normally perpendicular to the feature being dimensioned but may be drawn obliquely as shown for dimensioning tapers, parallel to each other. (Fig 6)

Arrangement and indication of dimensions

The arrangement of dimensioning on a drawing shall indicate clearly the design purpose.

The arrangements of dimensioning are:

- Chain dimensioning
- Dimensioning from a common feature
- Dimensioning by co-ordinates
- Combined dimensioning.

Chain dimensioning: It is used where the possible accumulation of tolerances does not infringe (effect) on the functional requirement of the component. (Fig 5)

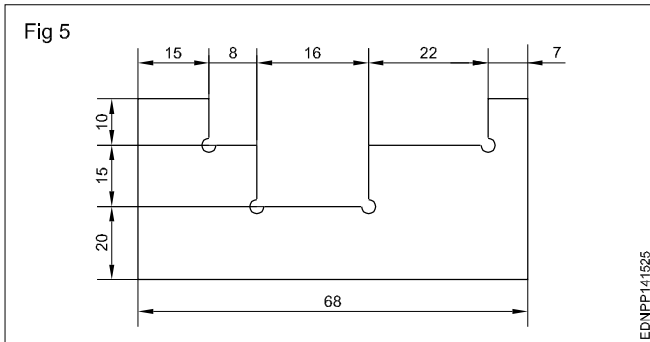

Dimensioning from a common feature is used where several dimensions of the same direction relate to a common origin.

Dimensioning from a common feature may be executed as parallel dimensioning or as superimposed running dimensioning.

Parallel dimensioning: Dimensions of features are taken from one datum/common origin and are shown parallel to another and placed so that the dimensional values can easily be added in Fig 6.

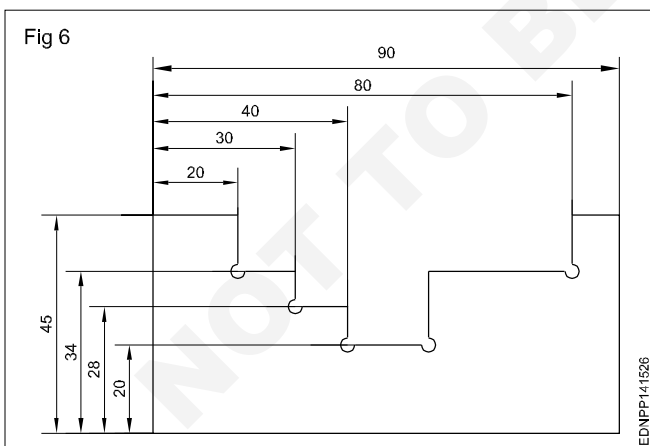

Superimposed running dimensioning (Progressive dimensioning): It is a simplified dimensioning. Also, the cumulative error is controlled. It starts from one origin with arrowheads in one direction only. This may be used where there are space limitations and where no legibility problems would occur.

The origin indication is placed appropriately and the opposite ends of each dimension line shall be terminated only with

an arrowhead. It may be advantageous to use superimposed running dimensions in two directions. (Fig 7)

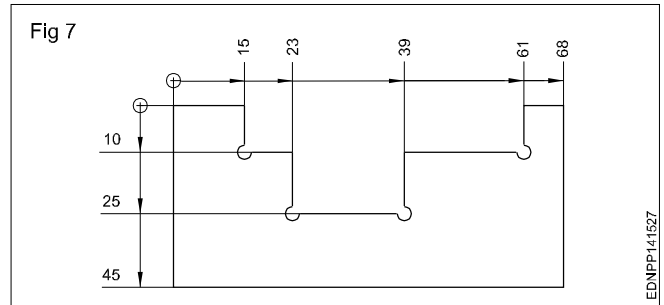

Dimensioning by co-ordinates: This system is much used for components, produced on a jig boring machine. Two edges are taken as a datum. (references)

Instead of dimensioning in a superimposed way, the same may be tabulated and given. (Fig 8)

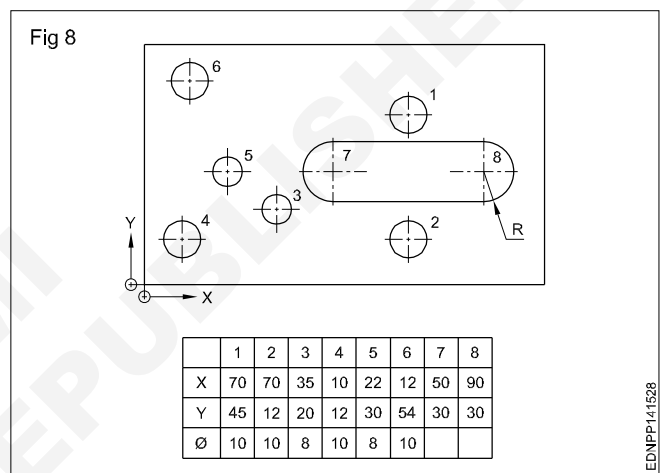

This method is useful in indicating places/positions in country, city and site plans.

Combined dimensioning: Dimensions are given in chain dimensioning and parallel dimensioning. The common feature is combined. (Fig 9)

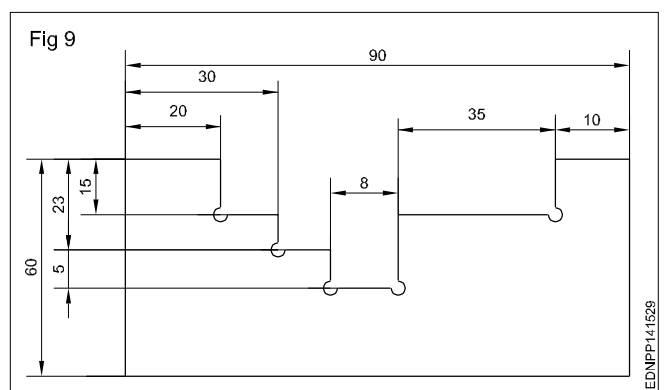

Methods of dimensioning common features

Dimensioning Tapered parts: When dimensioning tapered parts, extension lines be at an angle and parallel to each other. The dimension line is drawn parallel to the feature to be dimensioned. (Figs 10 & 11) They may sometimes be shown with large dia and or MT numbers.

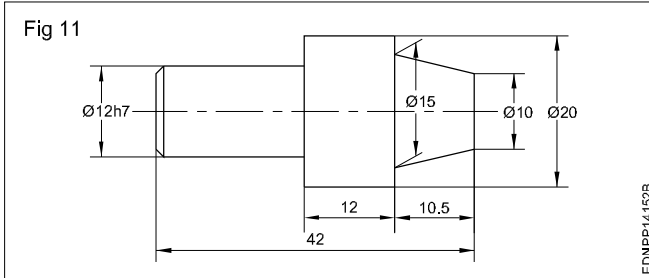
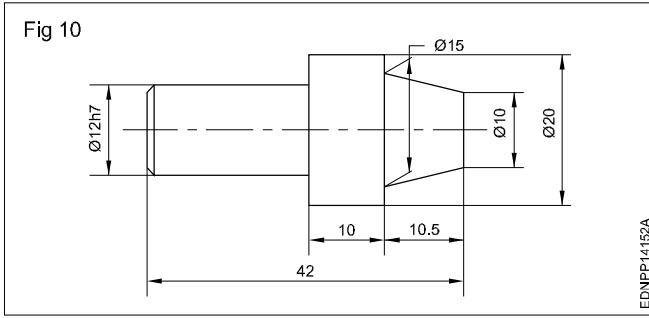

To avoid placing dimensions too far away from feature, dimension lines are drawn closer and not fully. (Fig 12)

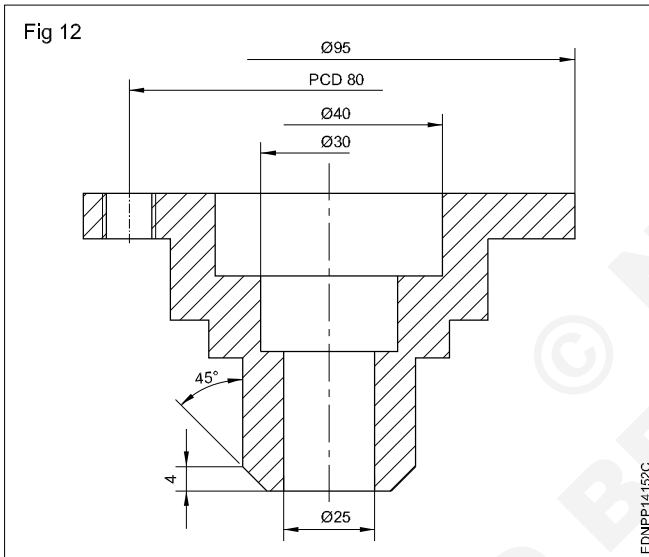

Dimensioning cylindrical and spherical features: Cylindrical features have diameter and length whereas sphere has a diameter only.

Diameter may be indicated by any one of the abbreviation D, Dia, d, dia or ϕ and radius may be indicated by R, r, Rad or rad by square. Any one abbreviation or symbol on a drawing may be indicated by SQ or \square .

The length if any required to give along with dia, if it is shown as ϕ ...x... long. (Fig 13)

- ϕ - Diameter
- R - Radius
- \square - Square
- SR - Spherical radius
- S ϕ - Spherical diameter

Dimensioning a chord: For dimensioning of the chord, refer Fig 14. It is shown as linear size.

Dimensioning an arc/radius: A small arc is shown over the dimension value, while dimensioning an arc. (Fig 15)

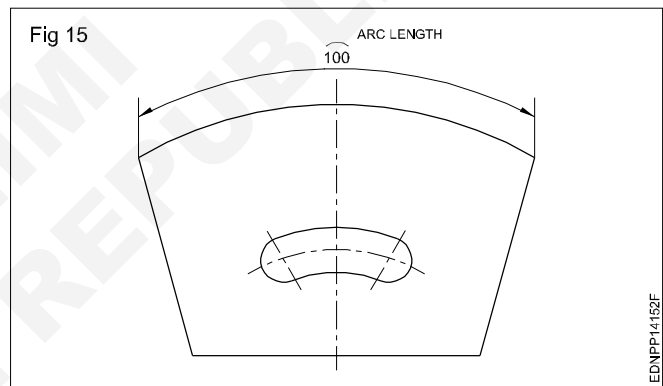
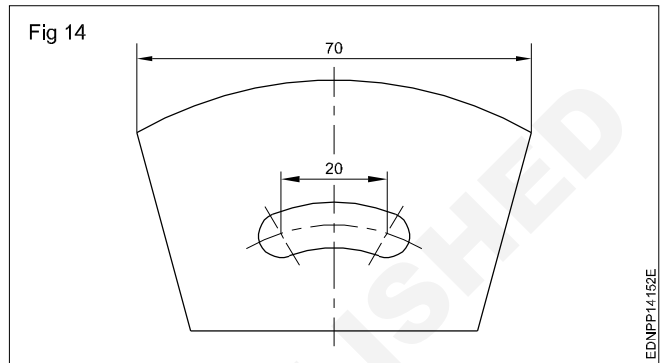
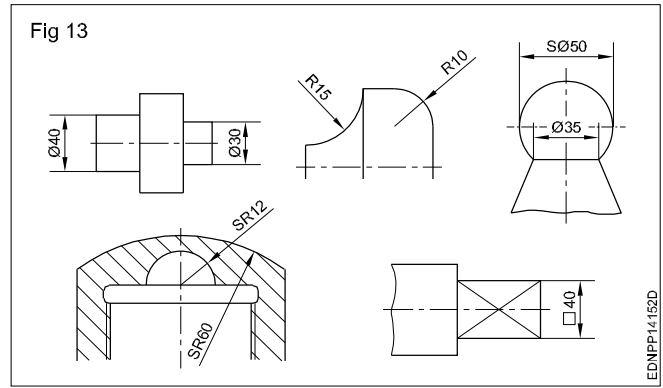

Dimensioning equidistant features: Where equidistant features or uniformly arranged elements are parts of the drawing, the specification of the dimensioning may be simplified. Linear spacing may be dimensioned as in Fig 16a&b.

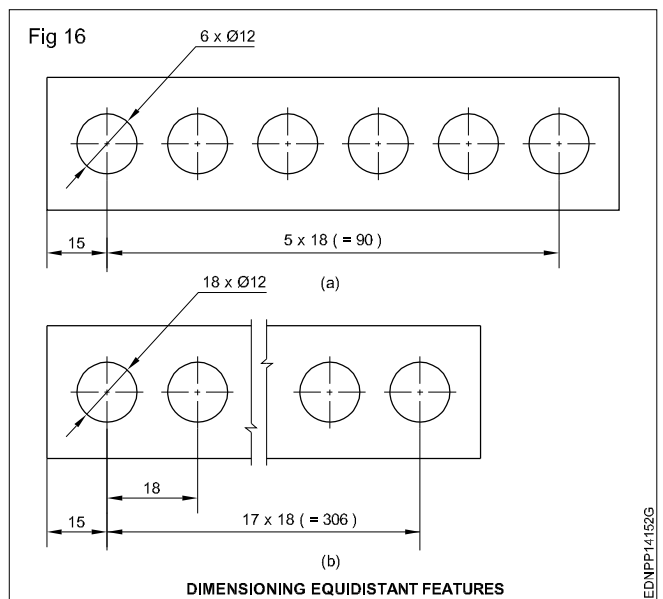

When the drawing is clear, symbols or abbreviation viz. dia, Pcd and angle can be omitted. (Fig 17)

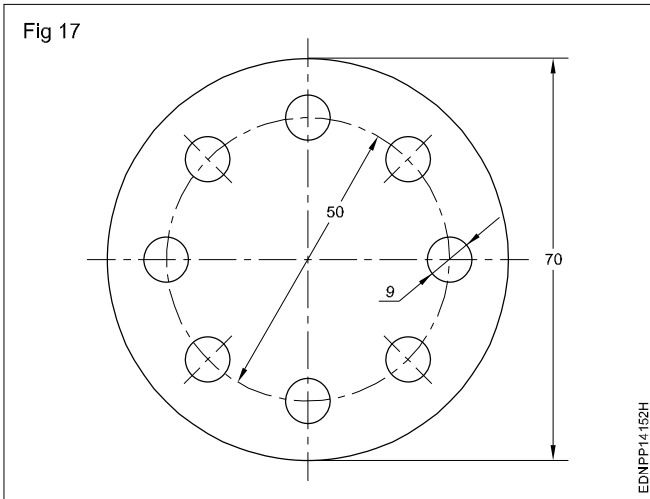

Dimensioning periphery: The features on the periphery can be shown as given in the figure, indicating width, depth and number of slots. (Fig 18)

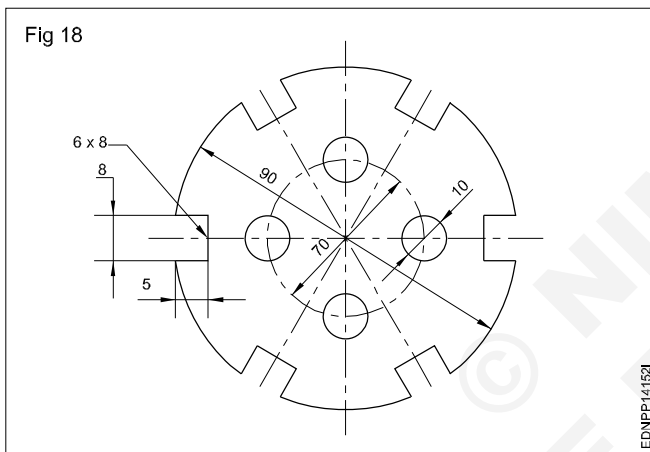

Dimensioning repeated features: When elements of the same size occur, but not of the same pitch be shown as in Fig 19.

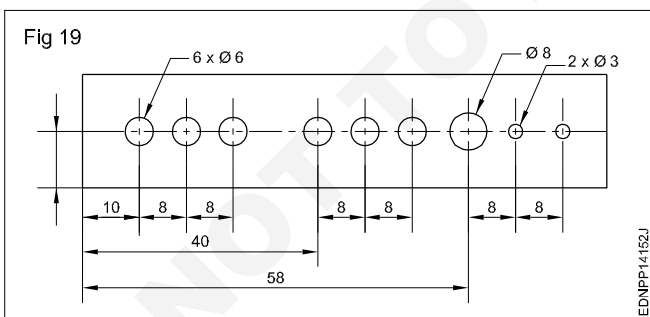

Countersinks and counterbore (IS:10968-1984): For simplification, the holes are indicated by centre lines and marked by different letters for different types/sizes of the hole. The holes may be plain, through the blind, tapped, countersink or counterbore. (Fig 20)

Dimensioning chamfers and undercuts: Chamfer of 45° may be shown by leader line indicating chamfer width and angle or by dimension line with chamfer width and angle. (Fig 21)

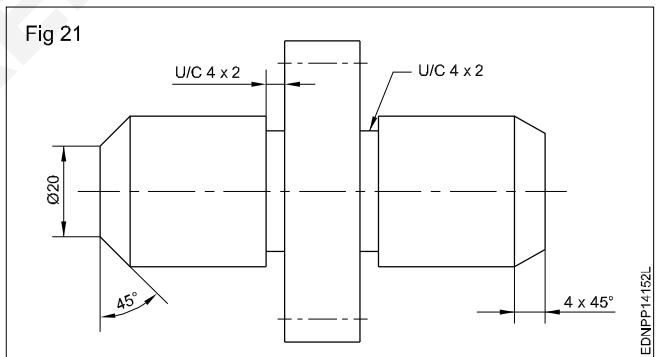
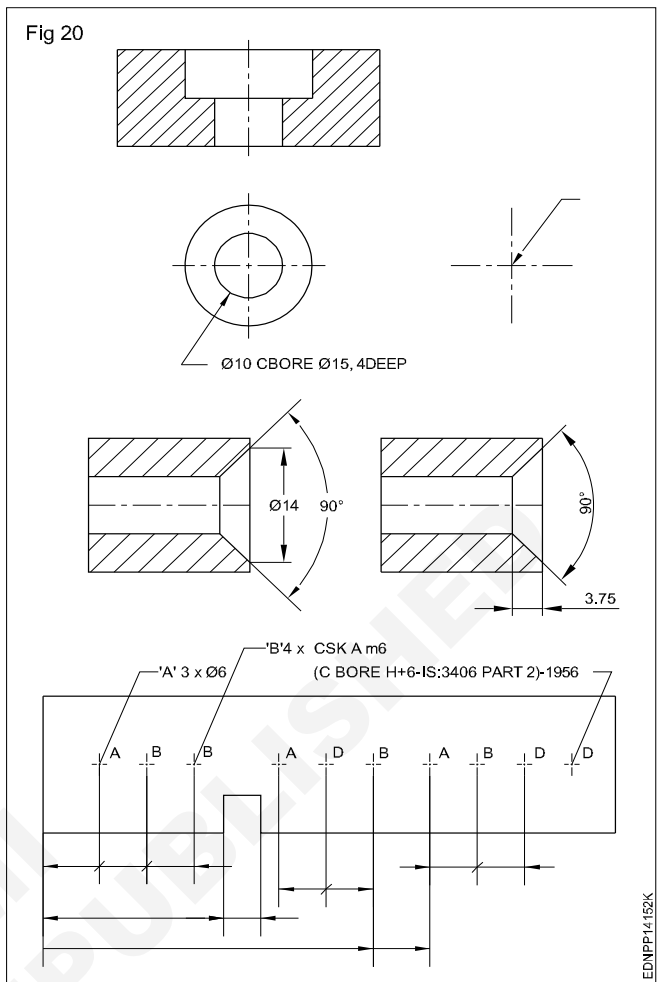

Indirect functioning dimensions (Fig 22)

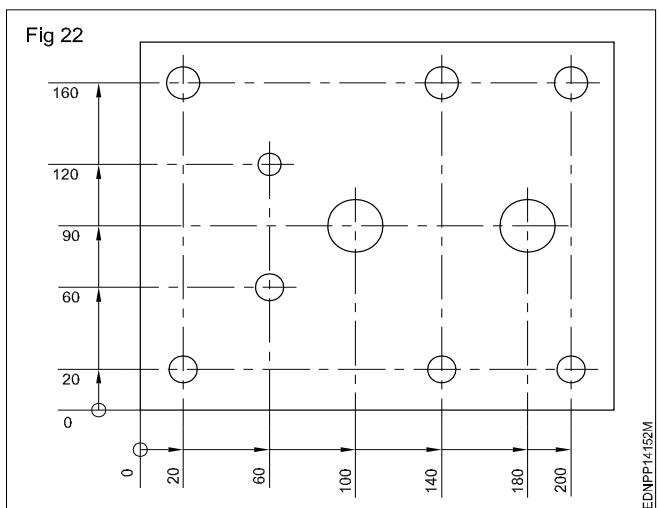

Practice of dimensioning

1 To the given drawing of the profile sheet metal as shown in Fig 1, place the dimensions in the aligned system. (Fig 1a)

- Draw the drawing of the sheet metal to 1:1 scale.
- Draw the extension lines in continuation of outlines.
- Draw the dimension lines. (Fig 1b)
- Place the dimension value near the middle and above the dimension line to be read from "bottom and right hand side" of the drawing.

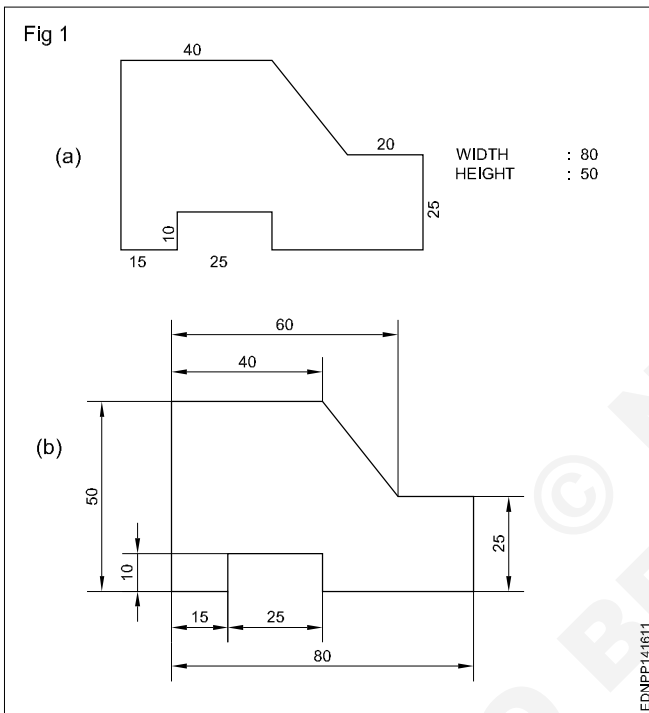

2 To the given drawing of the profile sheet metal as shown in Fig 2a, give the dimensions in the unidirectional system. (Fig 2b)

- Place the horizontal dimensions above and middle of the dimension line without break.
- Break the dimension in the middle of all non-horizontal dimension lines. (Fig 2b)

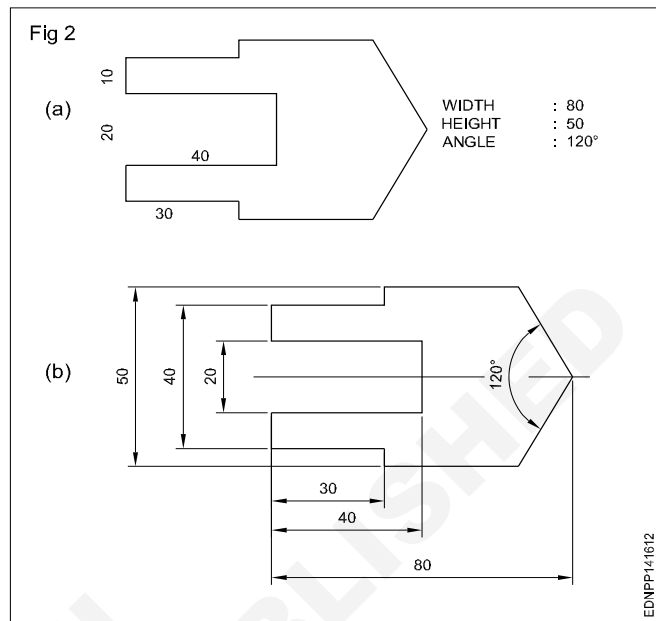

3 Draw the two sheet metal templates to full scale with appropriate lines use 0.5 range line thickness. (Fig 3)

- Draw a rectangular block of length 80 mm and width 50 mm in thin lines.
- Incorporate the features of the template as per the given dimension.
- Draw by thick lines all visible outlines.
- Give dimensions and maintain the line thickness as per the line range (0.5).
- Complete the figure and remove the unwanted lines.

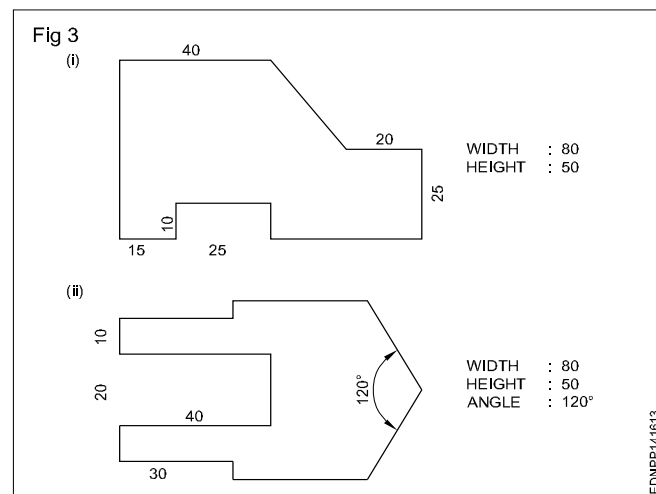

- 4 Draw the figures given. Maintain the types of lines as per the B.I.S and choose correct line thickness. (Fig 4)
- According to the given dimensions, draw the figures given in Fig 4.
 - Select the appropriate lines and maintain uniformity.
 - Remove (erase) unwanted lines, arcs and complete the drawing.

Note: Draw the dimension line terminations as per IS:11669-1986.

- 5 The motor cycle engine gasket is shown in figure 5. There are some mistakes in dimensioning. Reproduce the same in the A3/A4 sheet provided and correct the mistakes according to the aligned system of dimensioning. (Fig 5)

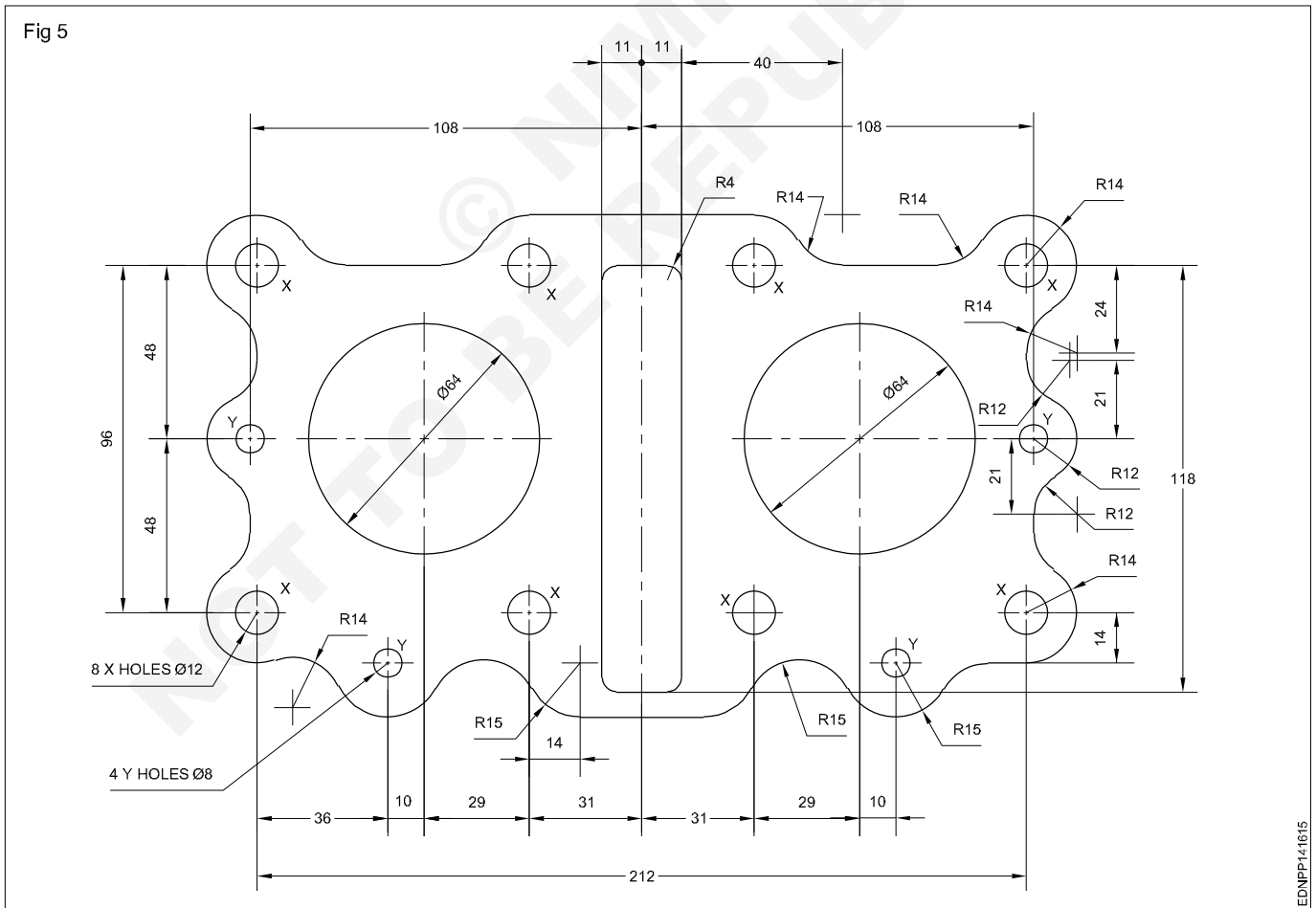
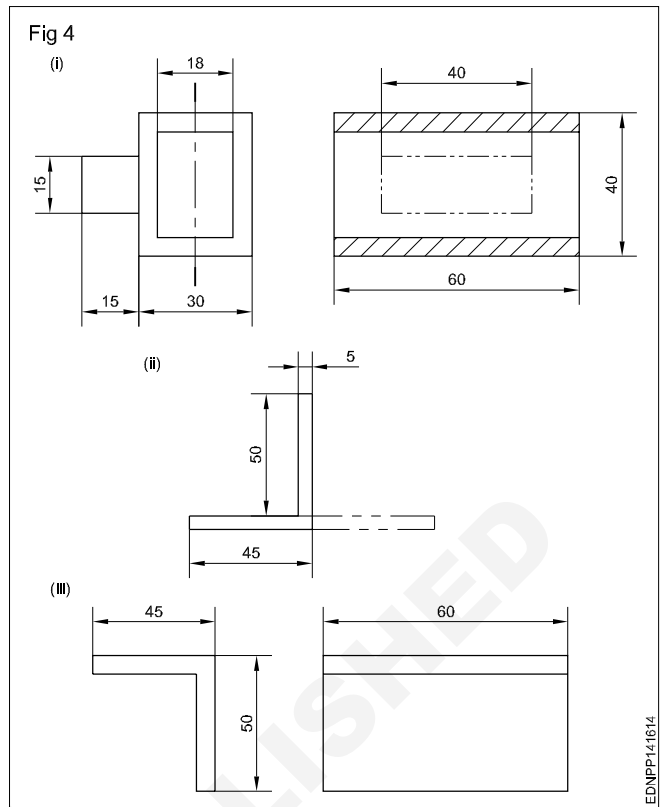

6 Draw the given cover plate and give the dimensions in the aligned system. (Fig 6)

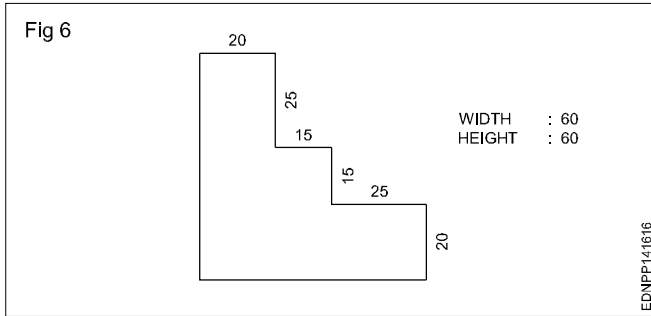

7 Draw the cover plate given in the figure and place the dimensions in the unidirectional system. (Fig 7)

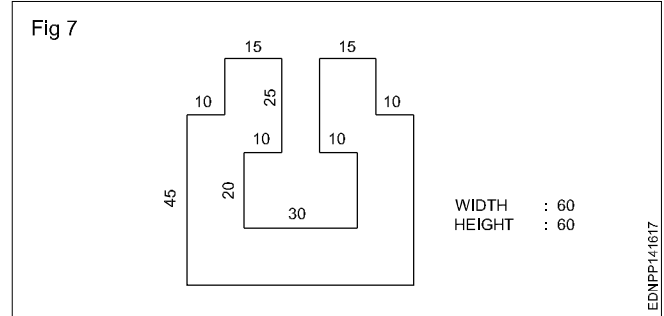









© NIMI
NOT TO BE REPUBLISHED



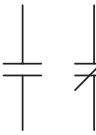
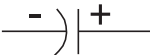

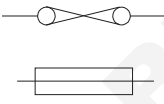

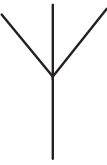

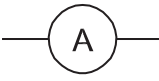
Different symbols used in the plastic processing operator trade

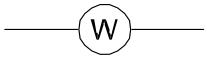
Sign and symbols for Plastic Processing Operator trade

S.No.	Description	Symbol
1	D.C.	
2	A.C.	
3	Positive	
4	Negative	
5	Single Phase A.C. 50 Hz	
6	Three Phase A.C., 50 Hz	
7	A.C. / D.C.	
8	3-Phase line	
9	Neutral line	
10	Earth	

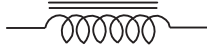

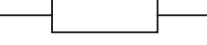
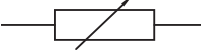

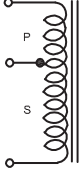
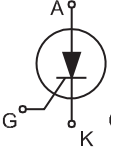

S.No.	Description	Symbol
11	Cell	
12	Battery	
13	Single pole single throw switch	
14	Push-button switch	
15	Energy meter	
16	Alternator	
17	Generator	
18	D.C. Motor	

S.No.	Description	Symbol
19	A.C.Motor Single phase	
20	3-phase squirrel cage motor	
21	3-phase slip ring motor	
22	Capacitor: Fixed, variable	
23	Electrolytic Capacitor	
24	Two-way switch	
25	Fuse: ordinary cartridge	
26	Socket 2 pin, 3 pin	
27	Aerial / Antenna	
28	Voltmeter	
29	Ammeter	

S.No.	Description	Symbol
30	Ohm Meter	
31	Watt Meter	
32	Lamp	
33	Buzzer	
34	Connections: star, Delta	
35	Choke	
36	Transformers	
37	Resistor : Fixed	
38	Resistor: variable	
39	Diode	
40	Auto transformer	
41	SCR	









S.No.	Description	Symbol
42	UJT	
43	SPS T switch	
44	DPS T switch	
45	SPD T switch	
46	DPD T switch	
47	Single Pole 5 way rotary switch	
48	SPDT slide switch	
49	Relay contacts	
50	Transformer tapped secondary	
51	Shielded wire	
52	Zener diode	
53	Schottky diode	
54	Diac	

S.No.	Description	Symbol
55	SCR	
56	TRIAC	
57	PNP transistor	
58	NPN transistor	
59	FET N-channel	
60	FET P-channel	
61	Unijunction transistor	
62	LED diode	
63	Photo voltaic cell	

Symbol	Description	Commonly found in
	Polyethylene Terephthalate	Soda, water, and beer bottles; salad dressing containers
	High Density Polyethylene	Milk jugs; household cleaner containers; juice bottles; yogurt tubs
	Vinyl	Shampoo bottles; cooking oil bottles; medical equipment; piping
	Low Density Polyethylene	Squeezable bottles; shopping bags; carpet; frozen food; food wraps
	Polypropylene	Yogurt containers; ketchup bottles; syrup bottles; medicine bottles
	Polystyrene	Meta trays; egg cartons; disposable plates and cups
	Miscellaneous	Sunglasses; iPod cases; computer cases; bullet-proof materials













PRESSURE CONTROL VALVES AND FLOW CONTROL VALVES

Table 3

	PRESSURE LIMITING VALVE
	SEQUENCE VALVE
	PRESSURE REGULATOR. NO RELIEF PORT
	PRESSURE REGULATOR. WITH RELIEF PORT
	RESTRICTOR VALVE
	ORIFICE VALVE
	ADJUSTABLE RESTRICTOR VALVE
	RESTRICTOR VALVE. MECHANICALLY ADJUSTABLE BY LEVER ACTUATOR SPRING RETURN
	SHUTOFF VALVE

ENERGY TRANSMISSION

Table 6

	PRESSURE SOURCE
	WORKING LINE
	PILOT OR CONTROL LINE
	EXHAUST LINE
	DASH DOT DOT - ENCLOSURE TO INDICATE ASSEMBLY OR COMBINED GROUP
	ELECTRICAL LEAD
	FLEXIBLE LINE
	LINES JOINING
	LINES PASSING (NOT JOINED)
EXHAUST POINTS	
	NO PIPE CONNECTION
	CONNECTED TO PIPE
PRESSURE CONNECTION	
	PLUGGED
	CONNECTING LINE

ENERGY CONTROL AND REGULATION

Table 5

DIRECTIONAL VALVES	
	2/2 WAY VALVE FLOW P TO A CLOSED IN NORMAL POSITION
	2/2 WAY VALVE FLOW P TO A OPEN IN NORMAL POSITION
	3/2 WAY VALVE FLOW P TO A CLOSED IN NORMAL POSITION
	3/2 WAY VALVE FLOW P TO A OPEN IN NORMAL POSITION
	3/3 WAY VALVE CLOSED CENTER (ALL PORTS CLOSED IN NORMAL POSITION)
	4/2 WAY VALVE
	4/3 WAY VALVE CLOSED CENTER (ALL PORTS CLOSED IN NORMAL POSITION)
	4/3 WAY VALVE OPEN CENTER (OPERATING OUTLETS B AND A OPEN TO EXHAUST. INLET P CLOSED IN NORMAL POSITION)
	CHECK VALVE
	SHUTTLE VALVE
	RESTRICTOR CHECK VALVE. ADJUSTABLE RESTRICTOR (SPEED CONTROL VALVE)
	QUICK - EXHAUST VALVE
	TWO - PRESSURE VALVE

OPERATORS

Table 4

	MANUAL	MECHANICAL	
	GENERAL		PLUNGER
	BUTTON		ROLLER
	LEVER		IDLE - RETURN ROLLER
	PEDAL		SPRING
ELECTRICAL		SPRING	
	SOLENOID		PRESSURE
	SOLENOID AND PNEUMATIC PILOT VALVE		BLEED
			DIFFERENTIAL PRESSURE

SYMBOLS OF FLUID POWER SYSTEM

ENERGY CONVERSION

Table 1

	COMPRESSOR
	VACUUM PUMP
AIR MOTORS	
	NON - REVERSING (SINGLE DIRECTION)
	REVERSING TWO DIRECTION
	LIMITED ROTATION

Table 1

FREQUENCY CLASSIFICATION SYMBOLS	
	DAILY
	WEEKLY
	MONTHLY
	SCHEDULED FOR FREQUENCIES OTHER THAN THOSE ABOVE

S.No.	Symbol	Description
1		Electric Motor
2		Hydraulic pump (Fixed displacement)
3		Hydraulic pump (Variable displacement)
4		Double acting cylinder
5		Single acting cylinder

S.No.	Symbol	Description
6		Filter
7		Cooler
8		Pressure gauge
9		Shutoff valve
10		Pipe below fluid level
11		Pipe above fluid level
12		Non return valve
13		Flexible pipe
14		Drain line
15		Pilot line
16		Enclosure (one unit)
17		Restriction
18		Pilot operated check valve
19		Throttle - valve
20		Pipe line junction
21		Pipe line cross over
22		Air bleed
23		Normally open contact
24		Normally closed contact
25		Limit switch open contact
26		Limit switch closed contact
27		Push button open contact
28		Push button closed contact
29		Rottary switch

S.No.	Symbol	Description
30		Relay coil
31		Time delay relay
32		Indicating lamp
33		Solenoid
34		Fuse
35		D.C. Valve hydraulically operated
36		D.C. Valve solenoid operated
37		D.C. Valve Electric hydraulic operated
38		Contact manometer
39		Relief valve direct operated
40		Relief valve pilot operated
41		Brake valve
42		Pressure releif valve direct operated
43		Presure releif valve pilot operated
44		Cartridge valve
45		Thermocouple
46		Thermal relay contact

Concept and reading of drawing in - Concept of axes plane and quadrant

An engineering drawing conveys many different types of information of which the most important thing is the shape of the object. Fig 1 shows a sample drawing. In this drawing, the shape of the part is represented by three views.

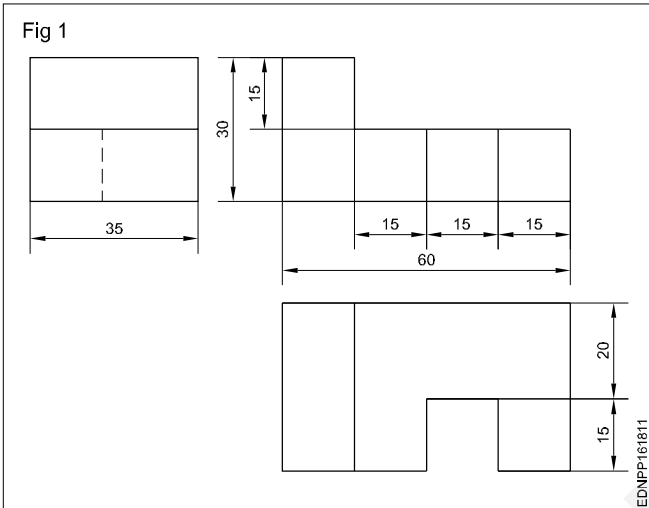

For an untrained person, it will be very difficult to conceive the shape of the object from the above drawing.

But in Fig 2, the same object is shown pictorially in a different way and the shape is easily understood even by a layman.

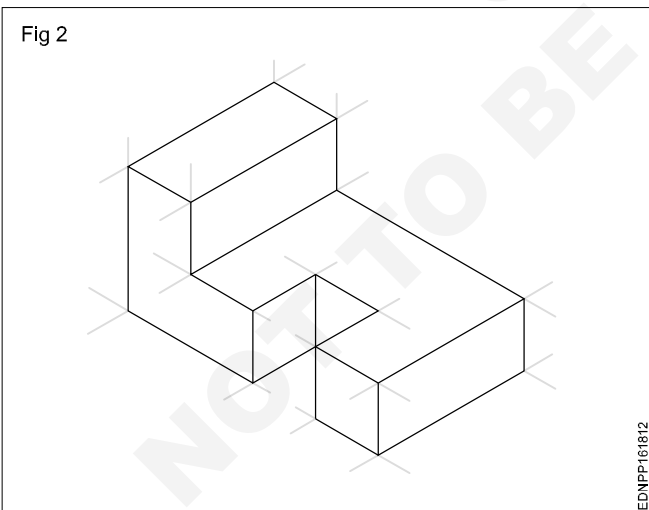
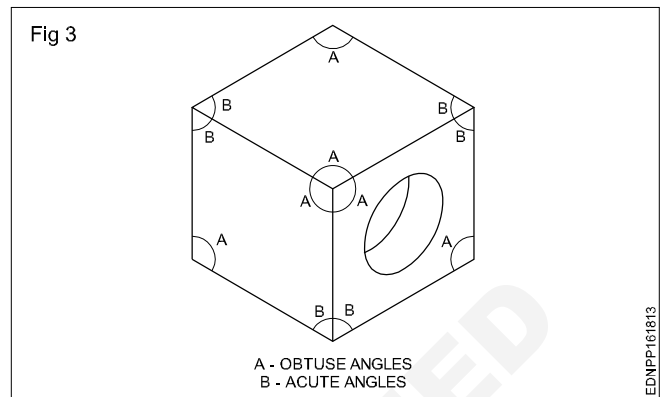

Figure 1 is called a Multiview drawing or Orthographic drawing and figure 2 is called a pictorial drawing.

Fig 3, wherein a cube with a circular hole is represented pictorially. We know that all corners of the cube are 90°. But in the pictorial drawing in Fig 3, the same 90° is represented at some places by acute angles and some other places by obtuse angles.



Projection: Projection is a commonly used term in draughtsman's vocabulary. In the context of engineering drawing, projectors mean images.

Projections or images can also be formed in between the eyes and the object by keeping a transparent plane. (Fig 4)

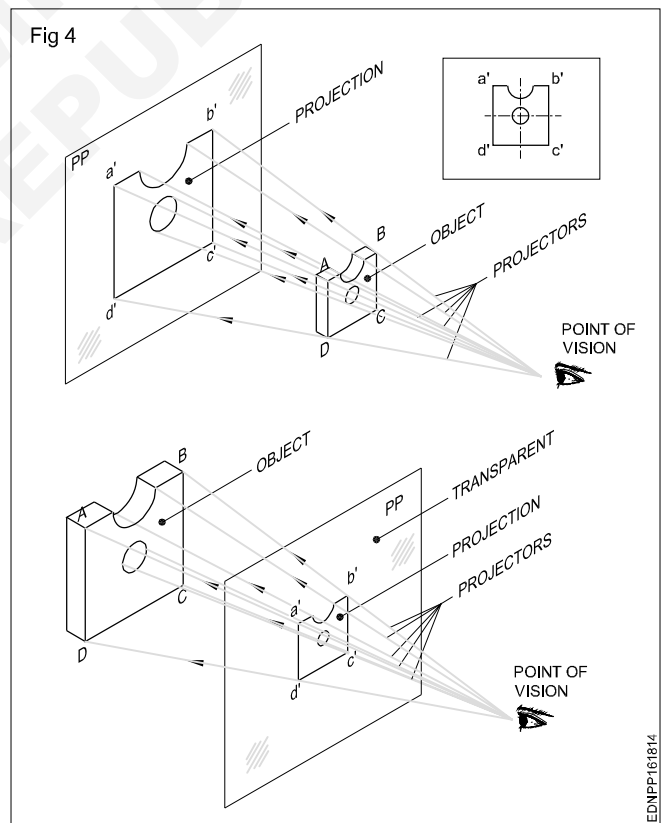

In this figure 4, the rays from the object converge to the eyes and this image (Projection) is smaller than the object. However, if the rays are parallel as in the case of rays coming from the sun, the image (Projection) will be of the same size as that of the objects. Such a projection is called

orthographic projection. The parallel lines/rays drawn from the object are called projectors and the plane on which the image is formed is called the plane of projection. In orthographic projection, the projectors are perpendicular to the plane of projection. (Fig 5)

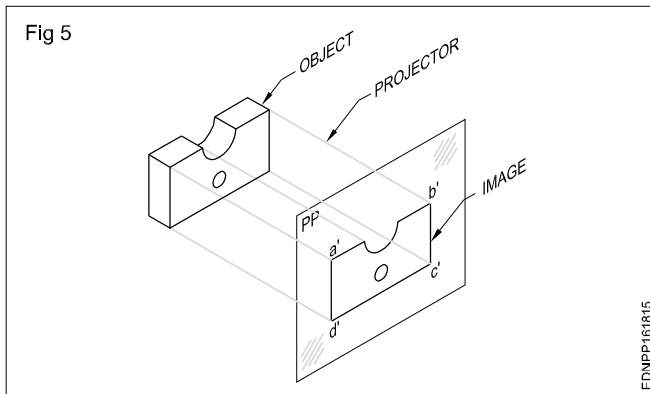

An orthographic system of projection is the method of representing the exact shape and size of a three-dimensional object on a drawing sheet or any other plain surface such as a drawing board.

A single orthographic view of an object will show only two of its three dimensions. The view in figure 6 shows only the length and height of the object alone.

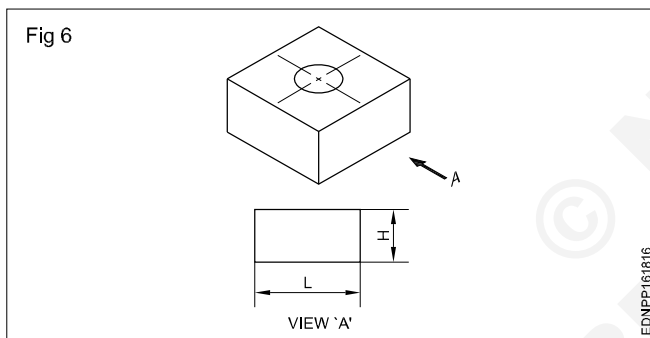

Therefore, it becomes necessary to have an additional view to show the missing dimensions (width). Hence, we have to make two views to represent the three dimensions of an object.

The two views thus required are to be obtained on two different planes which are mutually perpendicular (one HP and one VP) with the object remaining in the same position. The projection or the view obtained on the horizontal plane is called the top view or plan and the view obtained on the vertical plane is called elevation.

First angle and third angle projection: One vertical plane (VP) and one horizontal plane (HP) intersect at right angles to each other. (Fig 7)

All four quadrants have one HP and one VP formation. As per convention in mathematics, the quadrants are numbered as 1st, 2nd, 3rd and 4th. These four quadrants are called four dihedral angles, namely 1st angle, 2nd angle, 3rd angle and 4th angle.

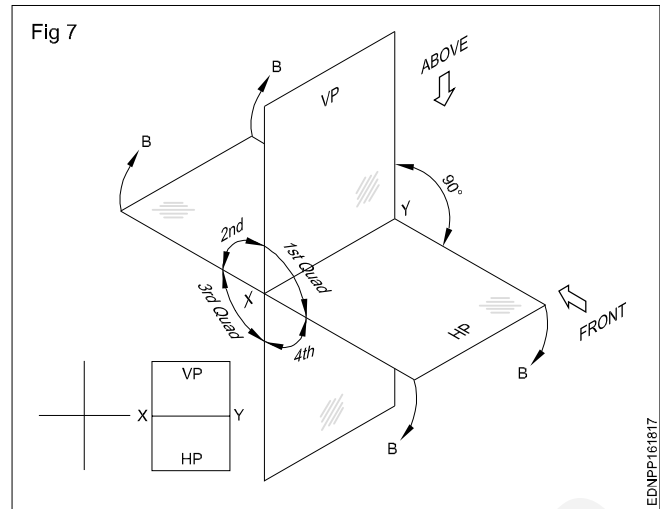

To draw two views of an object, we assume that the object is placed in any one of the quadrant/angles, 1st angle & 3rd angle (Fig 8a & 9a) and its top and front view are projected to the respective planes.

Now to make it possible to draw the two views (Front & Top view) in one plane i.e the plane of the drawing paper, the horizontal plane is assumed to be unfolded in a clockwise direction through 90° (Fig 8b & 9b). We proceed this way when the views are made. When the object is placed in the 2nd or fourth quadrant the front and top will get superimposed (one upon the other) (Fig 10a & b).

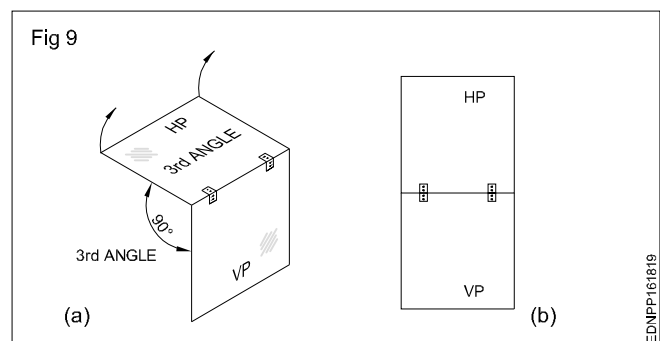
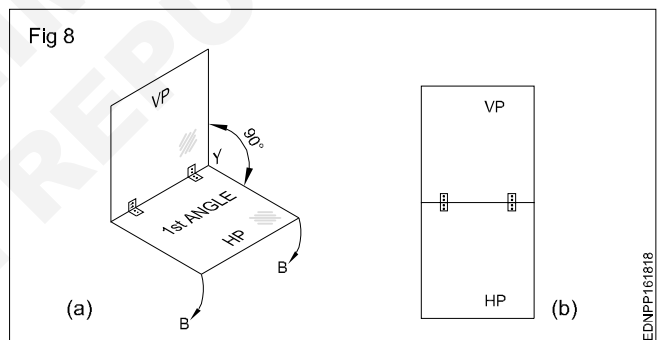

Due to this reason, the 2nd and 4th angles are not used for making engineering drawings as the three dimensions cannot be easily identified. Hence for representing the three dimensions of the object, we assume the object is placed either in the 1st angle or in the 3rd angle (Fig 11&12) respectively.

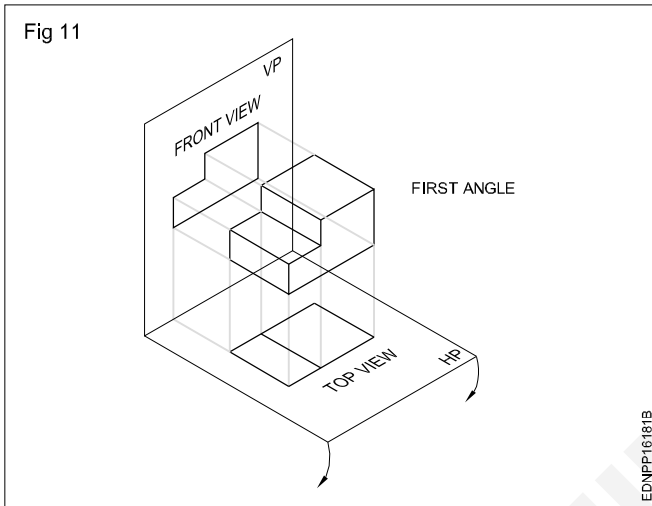
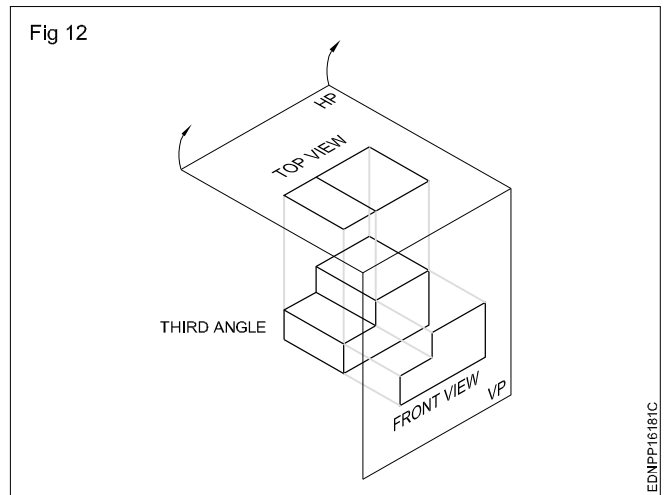
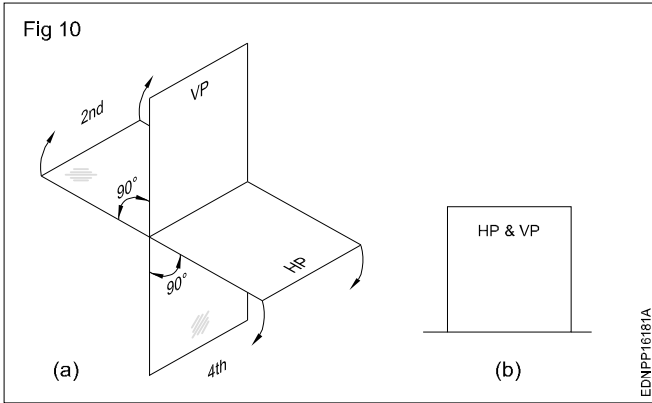

Concept and reading of drawing in - Concept of orthographic projection and isometric projections

Concept of Orthographic projection

Method 1

Draw the orthographic projection (front, top and side views) of the square sheet (40 mm side) kept perpendicular to HP and parallel to VP. (I angle) (Fig 1)

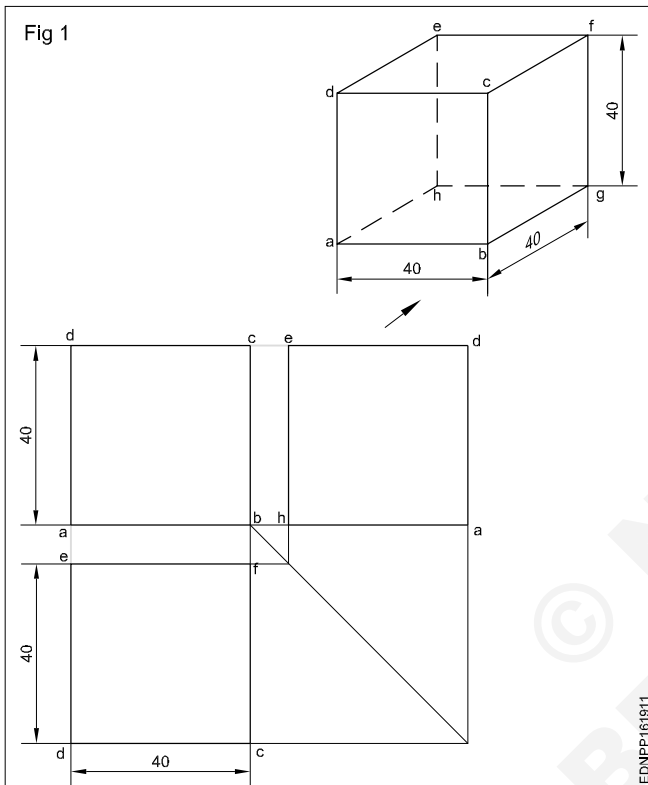

- Draw the XY line.
- Draw the square with its centre 40 mm above the XY line and one edge parallel to the XY line.
- Mark the corners of the figure a', b', c' & d'. This will be the front of the square.
- Draw the vertical projectors from a'b' downward beyond the XY line.
- Draw a horizontal line dc at a distance of 20 mm below the XY line. Line dc will be the plan.
- Draw a X'Y' line at a convenient distance from b'c', intersecting the XY line at 'O'.
- Project the top to the X Y line meeting at e.
- By arc method transfer Oe to XY and mark the point 'f' at a" and d" respectively. Now the line a"d" is the side view.

Method 2: Rectangular prism

Draw the Top, Front and side views of the rectangular prism of base 30 x 20 mm and height 40 mm. (Fig 2A)

In this exercise, the faces of the prism are parallel to the planes of projection. Therefore all the line's orthographic projections are vertical and horizontal only.

Visualise the shape of the object and imagine the shape description of views. Surface ABCD (Fig 2B) is only visible from the elevation. At the same time, all four sides of ABCD are isometric lines. Therefore in the elevation, a rectangle of 40 x 30 mm is seen.

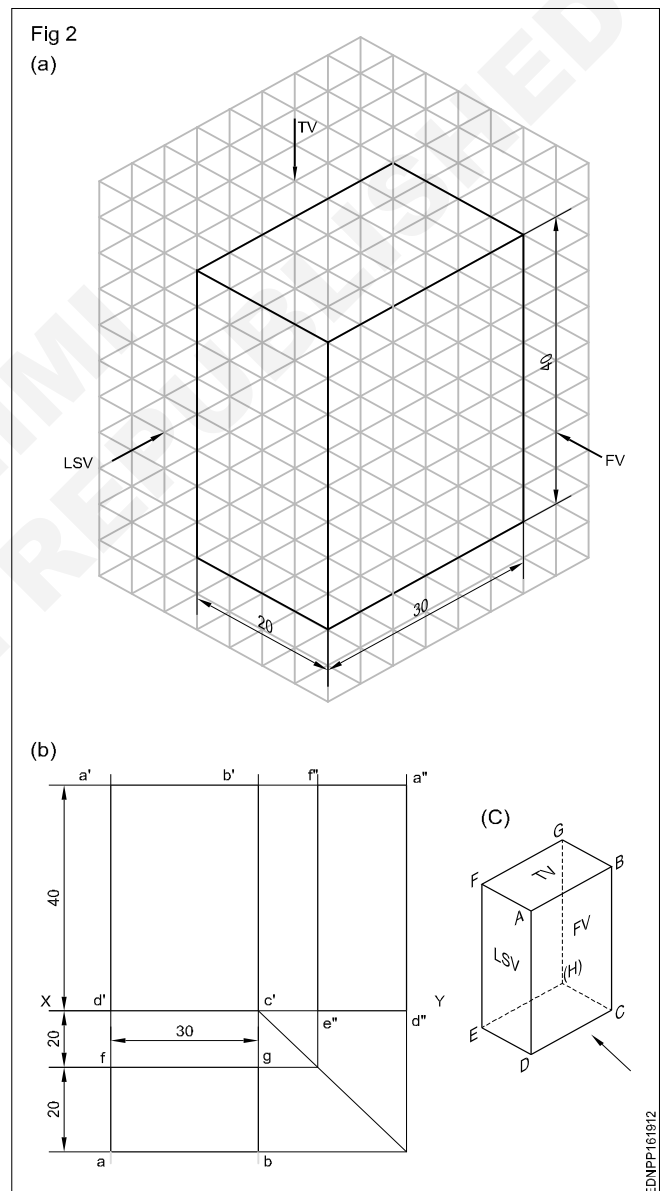

- Draw XY line of convenient length. (Fig 2B)
- Draw a rectangle a'b'c'd' on the XY line. This will be the front view of the prism.
- Project the vertical sides of the front view (a'd' and b'c') downwards beyond the XY line.
- Draw a horizontal line fg approximately 20 mm below the XY line.

- Draw a rectangle fgba of 30 x 20 mm size. This will be the plan of the prism.
- Project points b' and c' horizontally a convenient length to the right side of the elevation.
- Transfer the width of the top view GB by the arc and locate points e" d" on the XY line.
- Project e" d" vertically up and locate points f' a" d" e" is the left side view of the prism.

Method 3: Hexagonal prism

Draw the three views of the hexagonal prism shown in Fig3A.

From the position described above, it is clear that the hexagonal face of the prism is parallel to AVP. Therefore the end view is a true hexagon and hence this view should be drawn first.

- Draw the side view (hexagonal of side 25 mm) with one side on the HP line. (Fig 3B)
- Draw horizontal projectors from the side view and complete the front view. (in the front view two lateral faces are visible, but they are foreshortened).

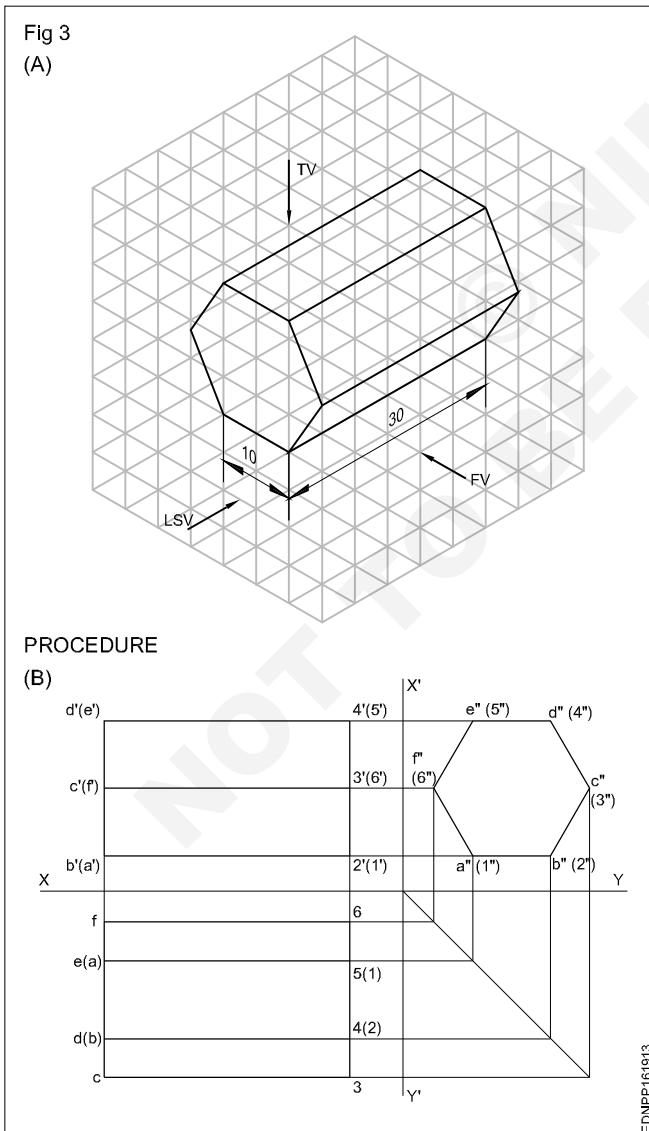

- Draw projectors from elevation and side view and complete the plan.
- (Three lateral faces are visible of which one is of true shape and the other two are foreshortened)

Method 4: Cylinder

Draw the top, front and side view of a cylinder of diameter 20 mm and length of 30 mm. (Fig 4A)

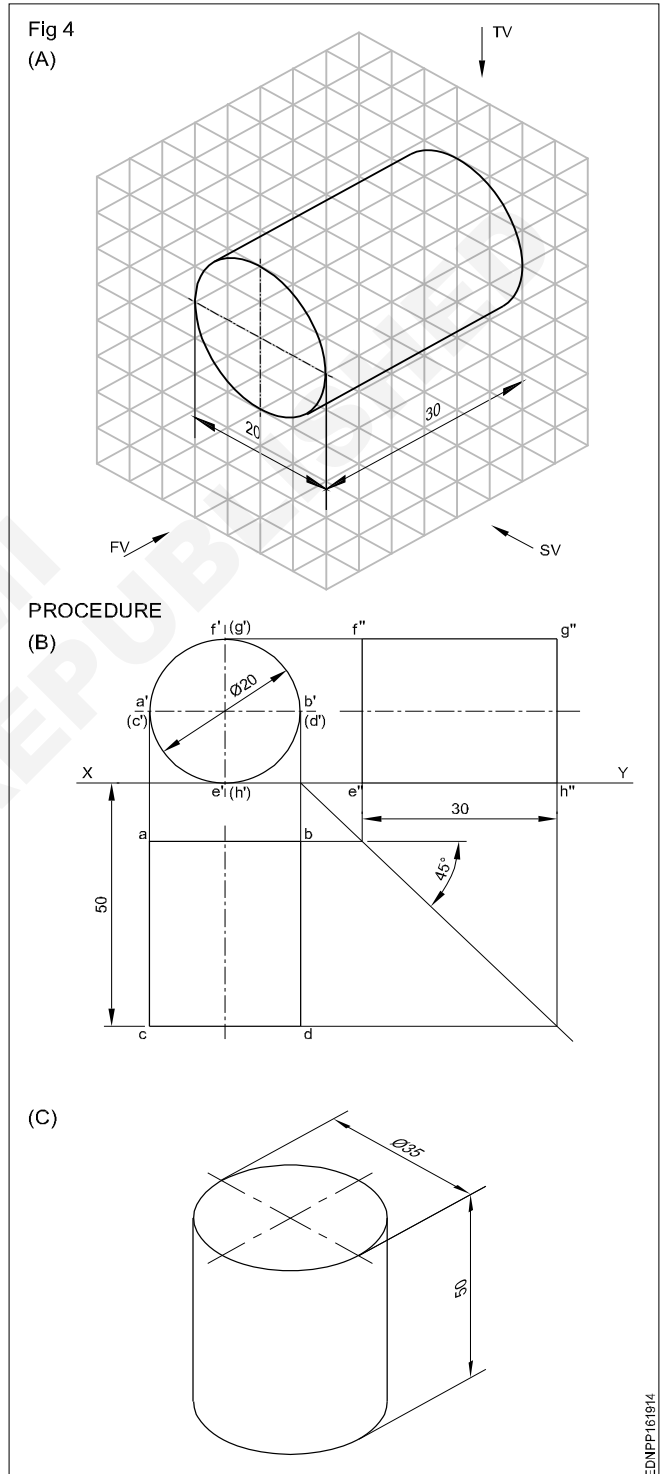

In this problem, the circular faces are parallel to VP. Therefore the front is a circle resting on the XY line. Plan and end views are rectangles of size 30 mm x 20 mm.

- Draw the circle of diameter 20 mm touching the XY line. (Fig 4B)

- Draw the plan projecting it from the elevation.
- Draw the end view by drawing a projection on it, from the plan and elevation.
- Draw the top, front and side views of a cylinder whose base diameter is 35 mm and height 50 mm when its position is as shown in Fig 4C.

Method 5: Cone

Draw the multi-views of the cone shown in Fig 5A. Follow the procedures of the earlier exercises and draw the multi-views. (Fig 5B)

Method 6

Identify the surfaces of the block shown in the isometric view with the corresponding multi-views and fill the numerals in the given tabulation column. (Fig 6)

The surfaces are parallel and perpendicular to the plane of projection.

- Study the isometric view and the corresponding multi-views carefully.
- You may observe that the surfaces seen in one view are represented by lines in the other two views.
- In this exercise, the surface 'A' shown in the isometric view is seen as a line in the front elevation and numbered as '5' in the front view of the corresponding multi-views.
- The same surface 'A' in the side view is seen as a line and numbered '6' in the side view of the multi-views.
- Similarly, the surface 'A' seen from the top of the isometric views is numbered as '10' in the plan of the multi-views, whereas the full surface area is visible.

When a surface is parallel or perpendicular to the plane of projection vice-versa in a multi-views drawing, the full area of the surface will be seen in any one of the three views (plan, elevation and side view) and in the other two views, the corresponding line of the surface will be seen.

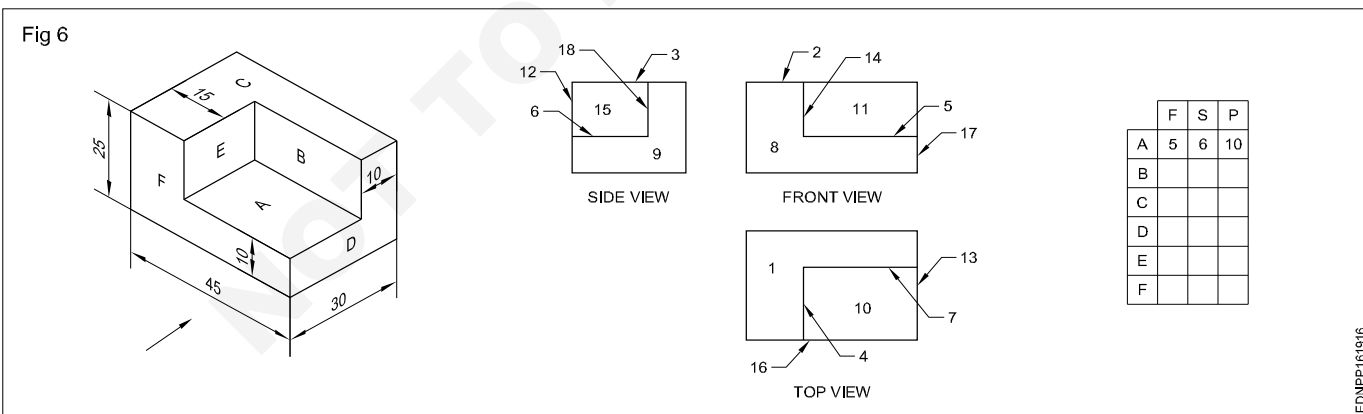
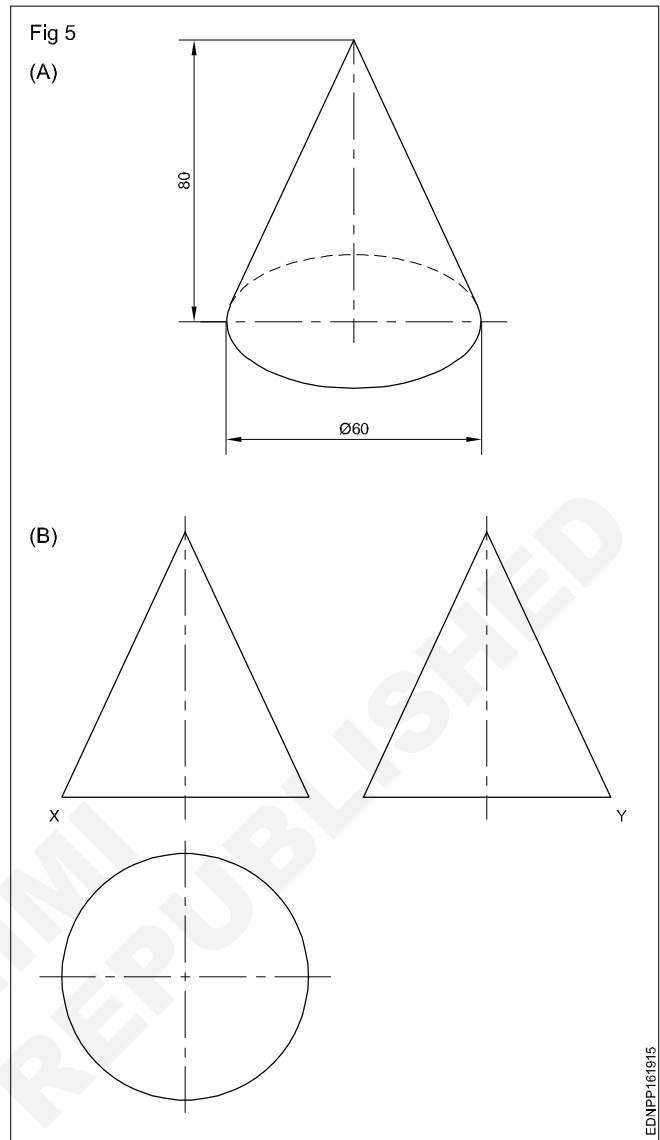

Method 7

Identify the surfaces of the block with slope cuts shown in the isometric view with the corresponding multi-views and fill the tabulation column. (Fig 7)

Surfaces B and F are inclined to HP and parallel to VP.

- You may observe that the surface inclined to one plane is seen in the other two views as the fore-shortened area of the surface and in another view the corresponding line of the surface is visible.

- In this exercise, the surface 'B' is seen as a surface in the front view and top view, numbered in multi-views as 7 & 8 respectively.
- The same surface 'B' in the side view is seen as a line and numbered as 19 in the multi-views which are shown in the tabular column. Study the drawing carefully and fill up the other columns.

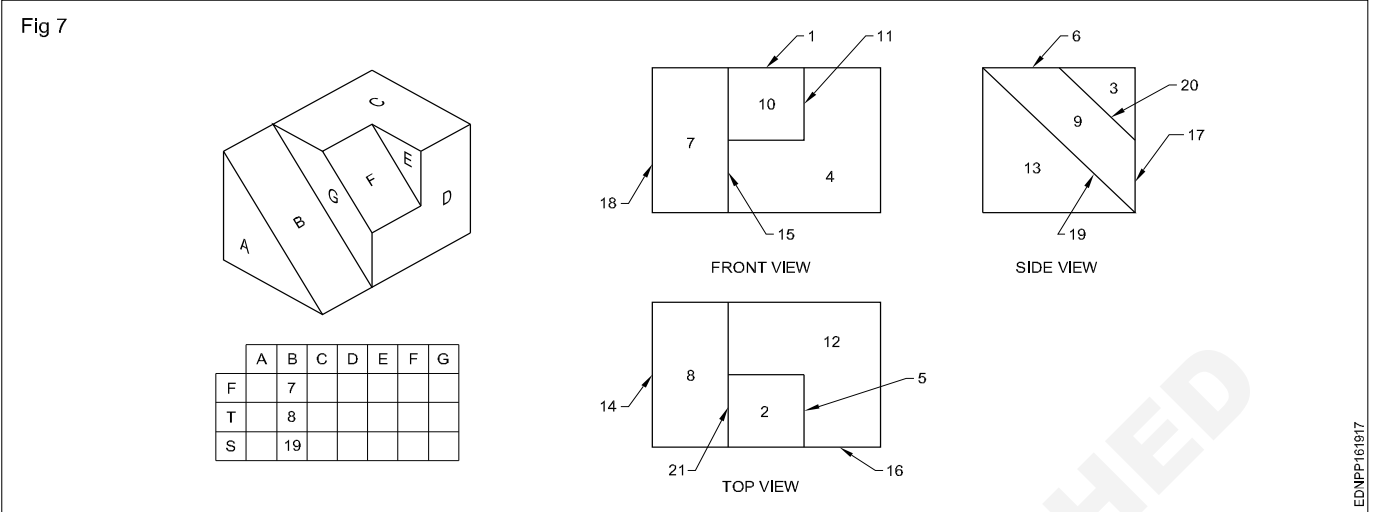

Method 8 (Fig 8)

Identify the surfaces of the block shown in the Isometric view with the corresponding multi-views and fill in the tabulation column. (Fig 8)

The surface is inclined to three planes HP, VP & AVP.

- In this exercise, you may observe that the surface 'A' is inclined to all three planes.
- When you visualise the surface 'A' in the front view of the isometric view, the fore-shortened area of the surface is seen and numbered as 2 in the multi-view.

- Seen from the top of the isometric view the fore-shortened area of the surface is seen and numbered as 5 in the top view of the multi-view. Similarly, inside view, it is numbered as 7 in multi-view.

When a surface of the object is inclined to all the planes, the complete fore-shortened surface will be seen in all three views.

- Fill in the other columns and complete the exercise.

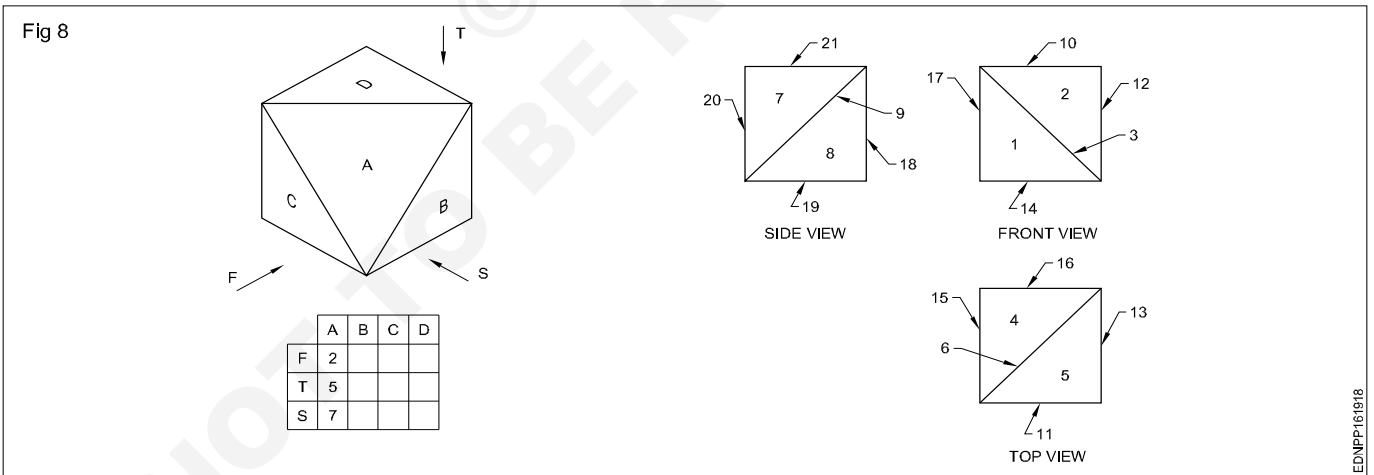

Method 9

Draw the isometric view (Fig 9) and also draw the three views in the workbook.

The orthographic projection shows the shape of a component by drawing several views each looking at a different side of the component.

A minimum of two views are required to represent a component. To clarify the internal and external details a minimum of three views are to be drawn. They are:

- Elevation or Front view or Front elevation. (F)
- Plan or Top view. (P)
- Side view or side elevation or end elevation. (S)

In Fig 9, surface 'A' is only seen when looking at the front of the figure. All the lines in the isometric view are isometric. Therefore in the orthographic projection, the front view will be like this. (Fig 10)

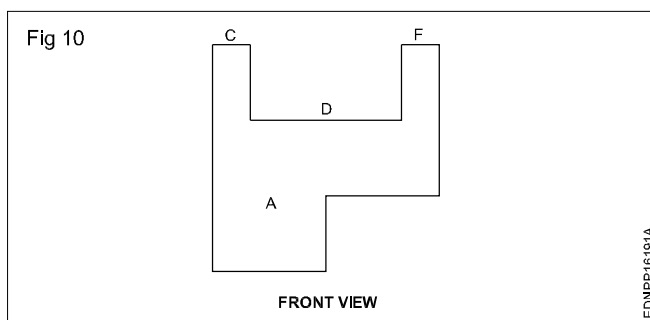
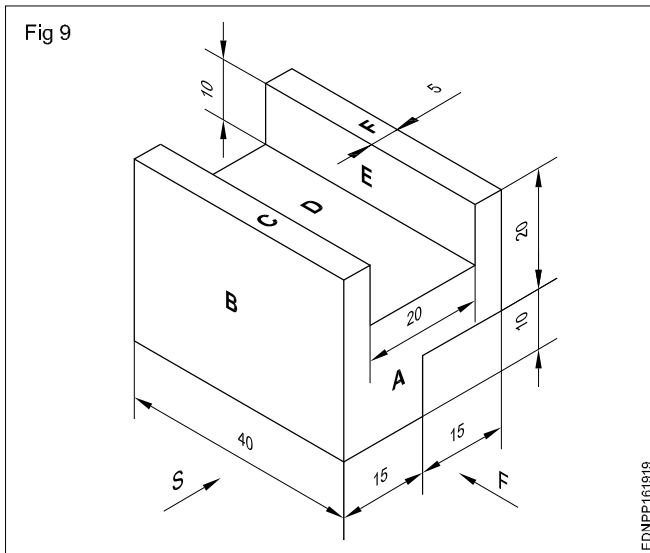

In the plan surfaces 'C', 'D' and 'F' are visible and the bottom surface will not be visible. The line joining the two surfaces will not be visible. The line joining the surfaces will appear in the plan as a hidden line. (Fig 11)

In the side view surface 'B' is visible and surfaces 'E' and back bottom surfaces are invisible. Due to this reason the line joining 'D' and 'E', also the line joining back bottom surfaces are appearing in the side view by a hidden line. (Fig 12)

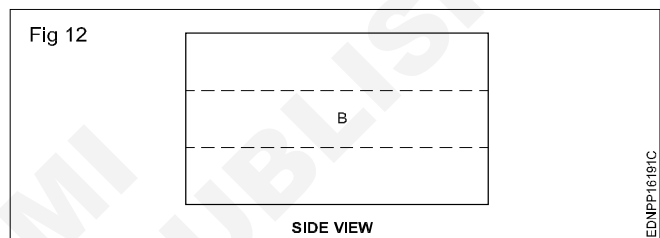
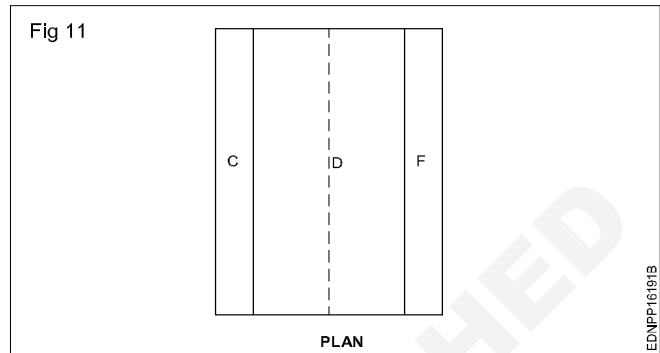

Pictorial drawing (isometric drawing)

Pictorial drawing: Even a common man can understand easily the shape of an object quickly by a picture or by a pictorial drawing. It is also called three-dimensional drawing.

Pictorial drawings are very useful for describing the shape of a piece part or component, even though they have a distorted look.

Three types of pictorial drawings are (Fig 1)

- Isometric drawing
- Oblique drawing
- Perspective drawing

Out of the above three types, isometric drawings are very much preferred by machine shops and metalworking trades groups. But perspective drawings are popular in the civil engineering group of trades.

Isometric drawing: In an isometric drawing the three mutually perpendicular edges of a cube are at an angle of 120° with each other. Instead of drawing the edges in an above-said way, first, we can also start from point 'a'. At this point also three mutually perpendicular edges met while two of these edges make 30° to horizontal, the other edge is vertical. After drawing two 30° lines and one vertical line, parallel lines are drawn to complete the cube. (Fig 2)

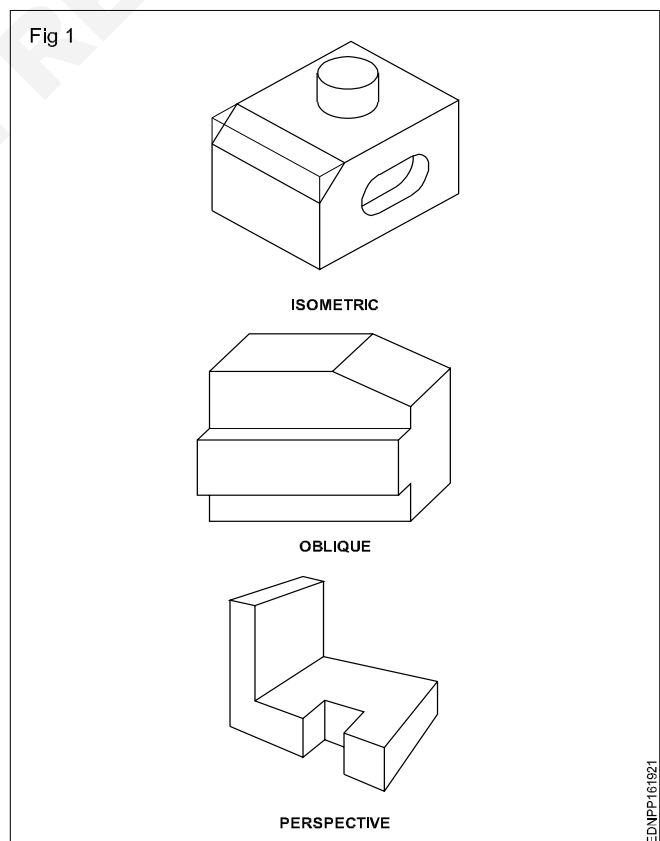

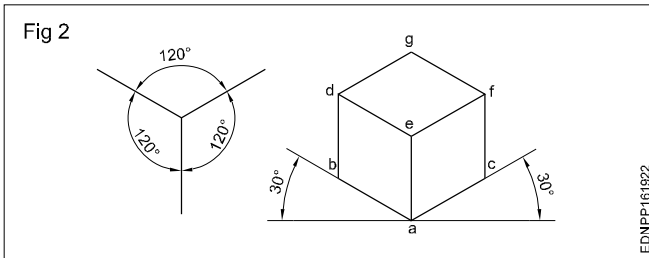

These three lines which represent the mutually perpendicular edges are isometric axes. Generally, those axes are kept in four positions. (Fig 3)

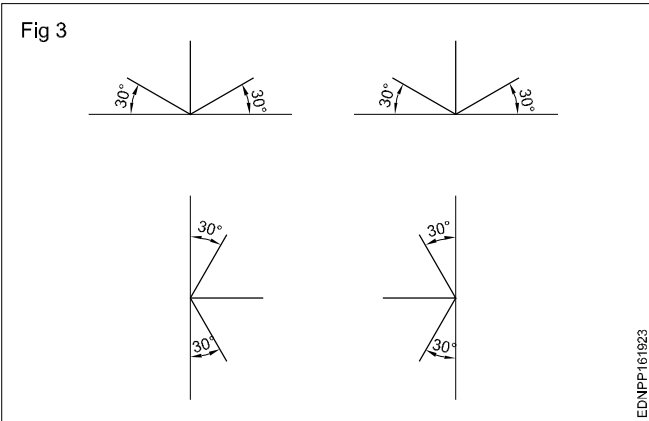

So to draw the isometric drawing, first draw the three mutually perpendicular edges, set other linear dimensions and complete the figure. (Fig 4)

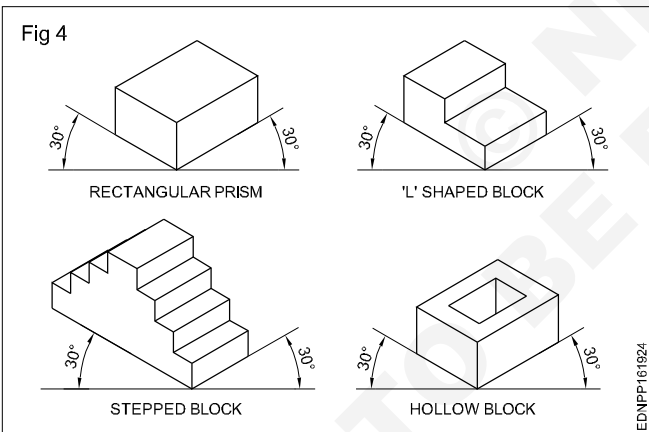

Angles in isometric drawing: The angles of inclined surfaces will not have the value in the isometric drawing, but will be more in some cases and less in other cases.

For example, in the isometric view of the prism shown in Fig 5 the true value of all the angles is 90° . But in isometric drawing, the angles are 60° in some cases and 120° in others.

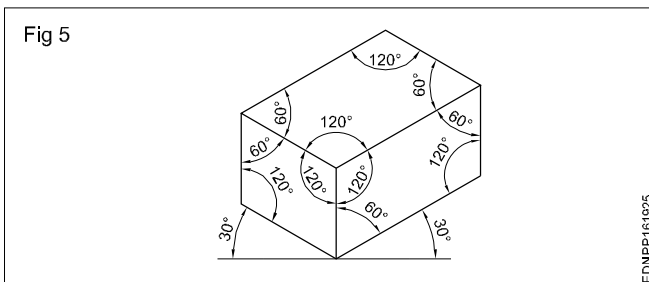

Isometric circles: The term isometric circle refers to the shape of a circle in an isometric view. An isometric circle will be elliptical as shown in Fig 6. While drawing an isometric view of cylindrical features isometric circles will have to be used. (Fig 7)

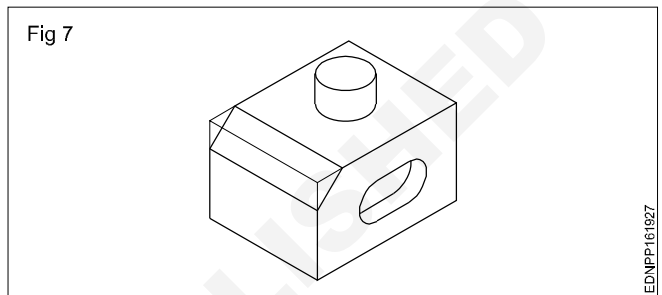
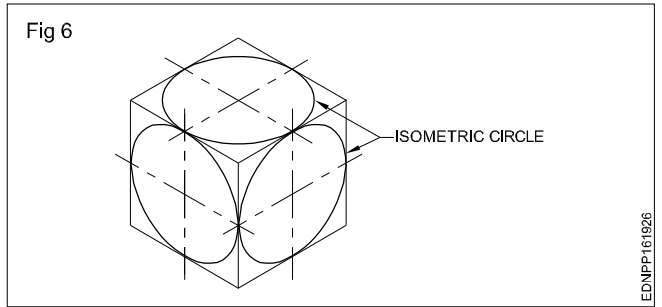

An isometric circle can be drawn either by the plotting method or by the arc method.

Plotting method (Fig 8)

- Draw a square of side equal to the dia of the circle and inscribe the circle.
- Divide the circle into any number of equal parts and mark points such as 1,2,3,4,5,6,7,8 on the circle.
- Through points, 1,2,3 etc draw lines parallel to both the axis of the cylinder.
- Draw an isometric view of the square.
- Mark points corresponding to 1,2,3,...8 with isometric view of the square as points 1',2',3',....8'.
- Join these points with a smooth curve for an ellipse.

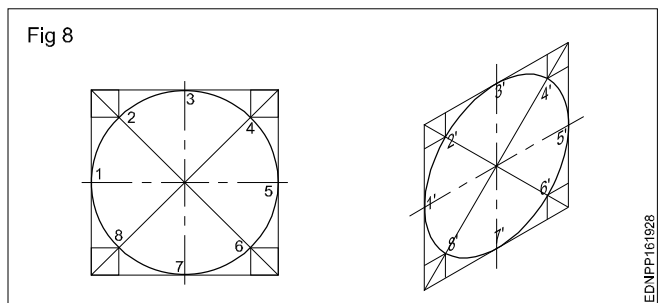

The orientation of the isometric circle will depend upon the plane on which the circular feature exists.

Arc method: Isometric circles drawn by offset method is the ideal method of making isometric circles as the ellipse obtained this way is geometrically true. But by freehand we cannot get a clear line.

Fig 9 shows the construction of an isometric circle in 3 different orientations by arc method. Four arcs are to be drawn and the centres as C1, C2, B & D. While centres B and D are the corner of the rhombus C1 and C2 are intersection points of the longer diagonal with lines from points B or D to the midpoint of the side of the rhombus.

The arc method gives a clean ellipse, but this ellipse drawn this way will slightly deviate from the true ellipse. It does not matter for our purpose.

The isometric circles can also be drawn using templates that can be bought from stationery shops.

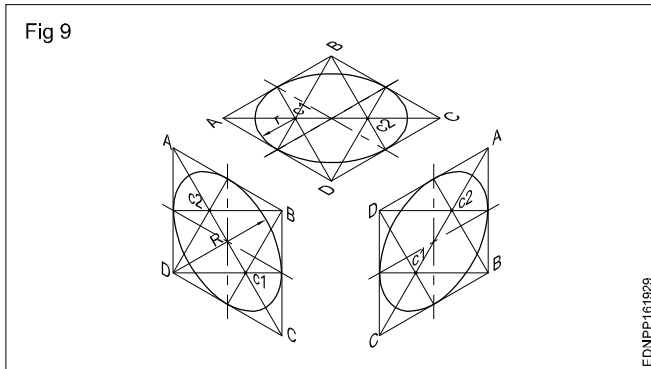

Isometric drawing

Procedure

1 Rectangular prism

Draw the isometric drawing of a rectangular prism of base 15 mm x 30 mm and the height of 50 mm. (Fig 1)

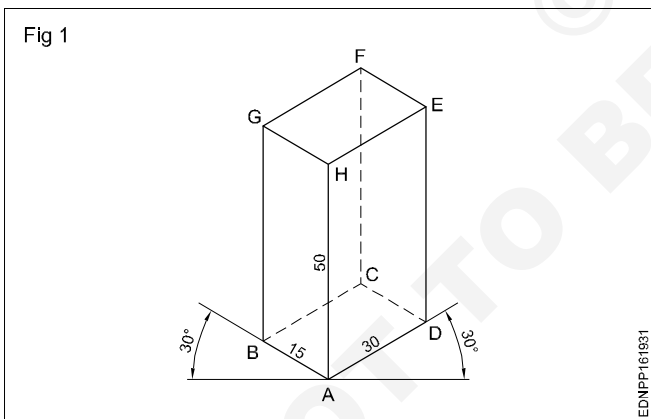

- Draw the three isometric axes through point 'A'.
- Mark AB = 15 mm, AD = 30 mm and AH = 50 mm representing the three sides of prism.
- Draw two vertical lines parallel to the line AH through points B and D.
- Similarly draw two more lines parallel to AB and AD through point H.
- Mark G and E the intersecting points.

- Draw lines parallel to GH and HE through points G and E intersecting point is F.
- Draw lines parallel to AB & AD through points D and B respectively intersecting at C.
- Join CB & CD with dash lines.
- Join F and C also with dash lines.
- Rub off the construction lines and complete the prism.

2 Stepped block - 1

Draw the isometric view of the stepped block given in Fig 2.

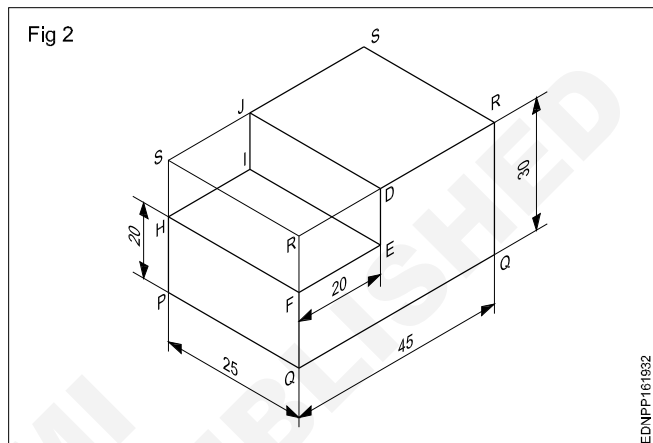

- Draw the isometric view of a rectangular prism of dimensions equal to the overall size of the block 45 x 25 x 30 mm.
- Draw the lines JD, DE, EF, FH, HI and IJ using the measurements given in the figure.
- Rub off SR, RD, SJ, SH and RF.
- Darken the remaining lines of the stepped block.

3 Stepped block - 2

Draw the isometric view of the components shown. (Fig 3)

- Draw the stepped block as per dimension. Follow the procedure given in the previous Ex. No.2.
- Mark points to UTSV as per dimension on the top of the surface EDGF (Fig 3b)
- Join points UTSV.
- Project vertically downwards from the points UTSV and obtain the point WXYZ at the bottom surface such that UW, TX, SY & VZ are equal to 10 mm. Join the point WXYZ and draw the thick lines which are all visible and dotted lines that are not visible

All construction lines should be in thin lines. After completion of the isometric views, in each case erase the unwanted lines and construction lines.

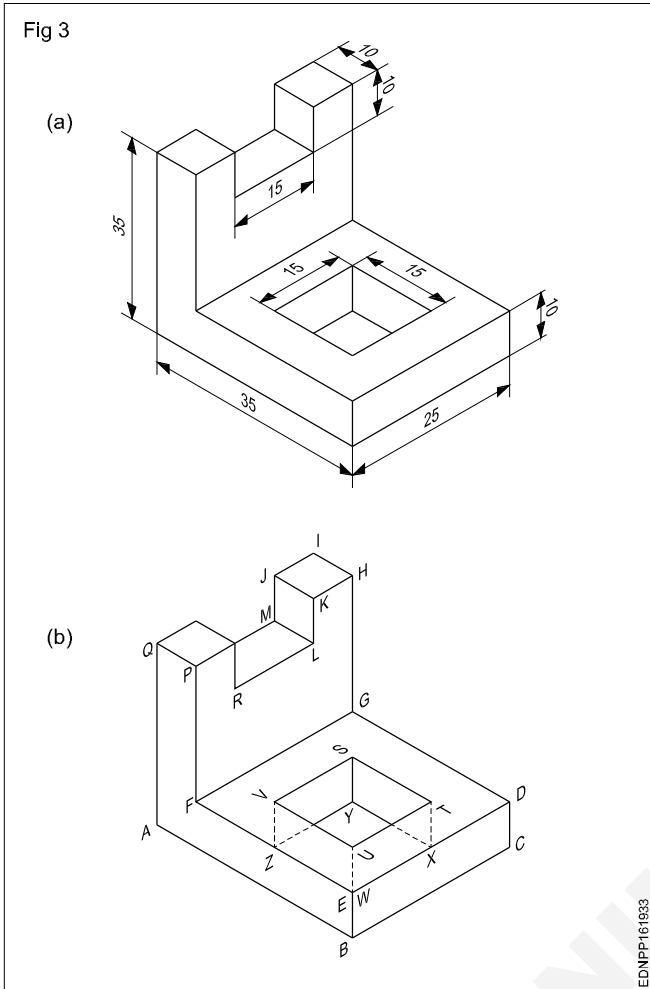

With the experiences gained in previous exercises of drawing isometric views, draw the following exercises 4 & 5 and complete the same.

Practice 1 to 3 (Figs 4,5 &6)

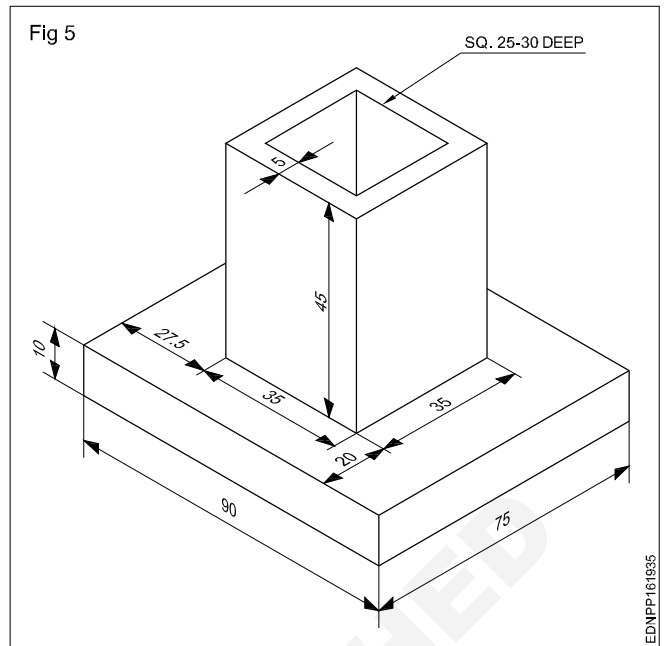
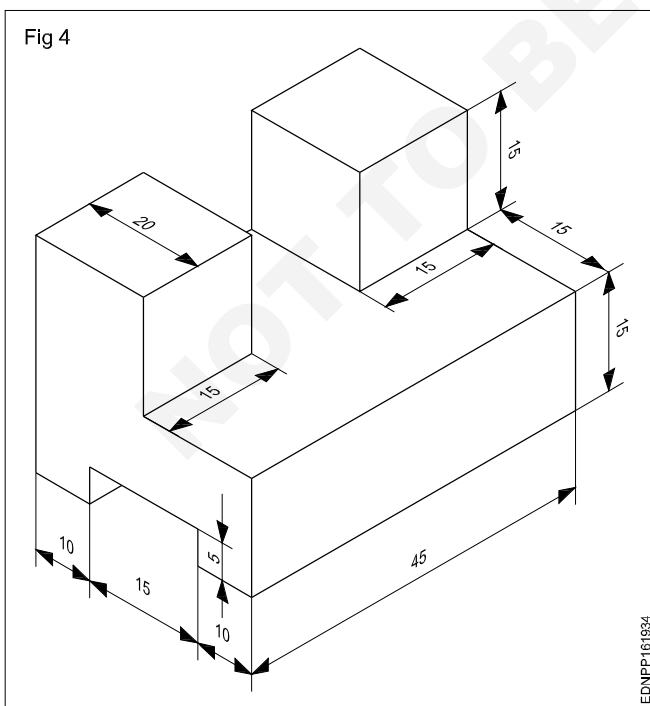

Draw the isometric view of the machined block having non-isometric lines. (Fig 6)

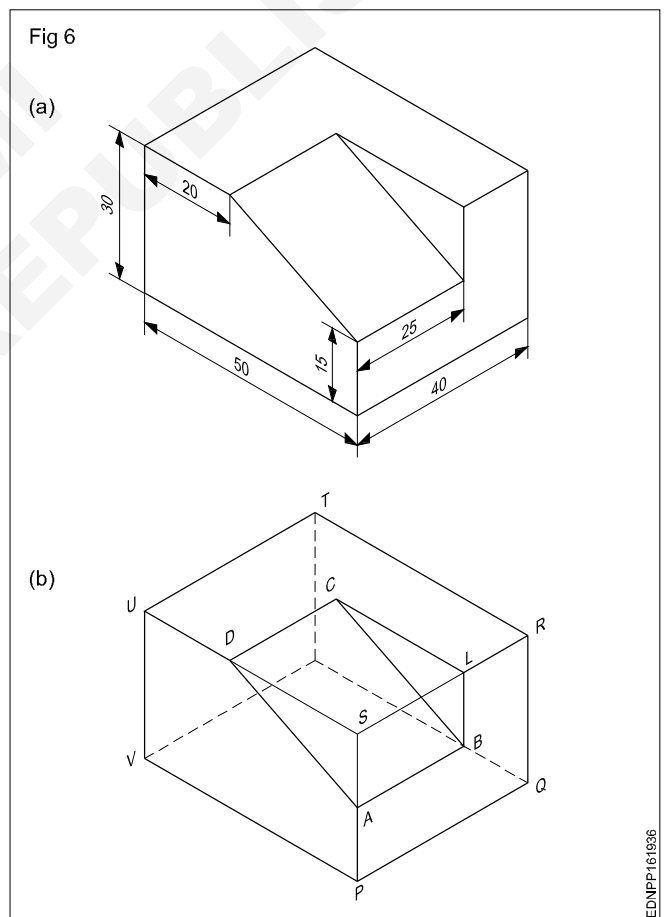

Method of 1st angle and 3rd angle projections (definition and difference)

Symbol of 1st angle and 3rd angle projection as per IS specification

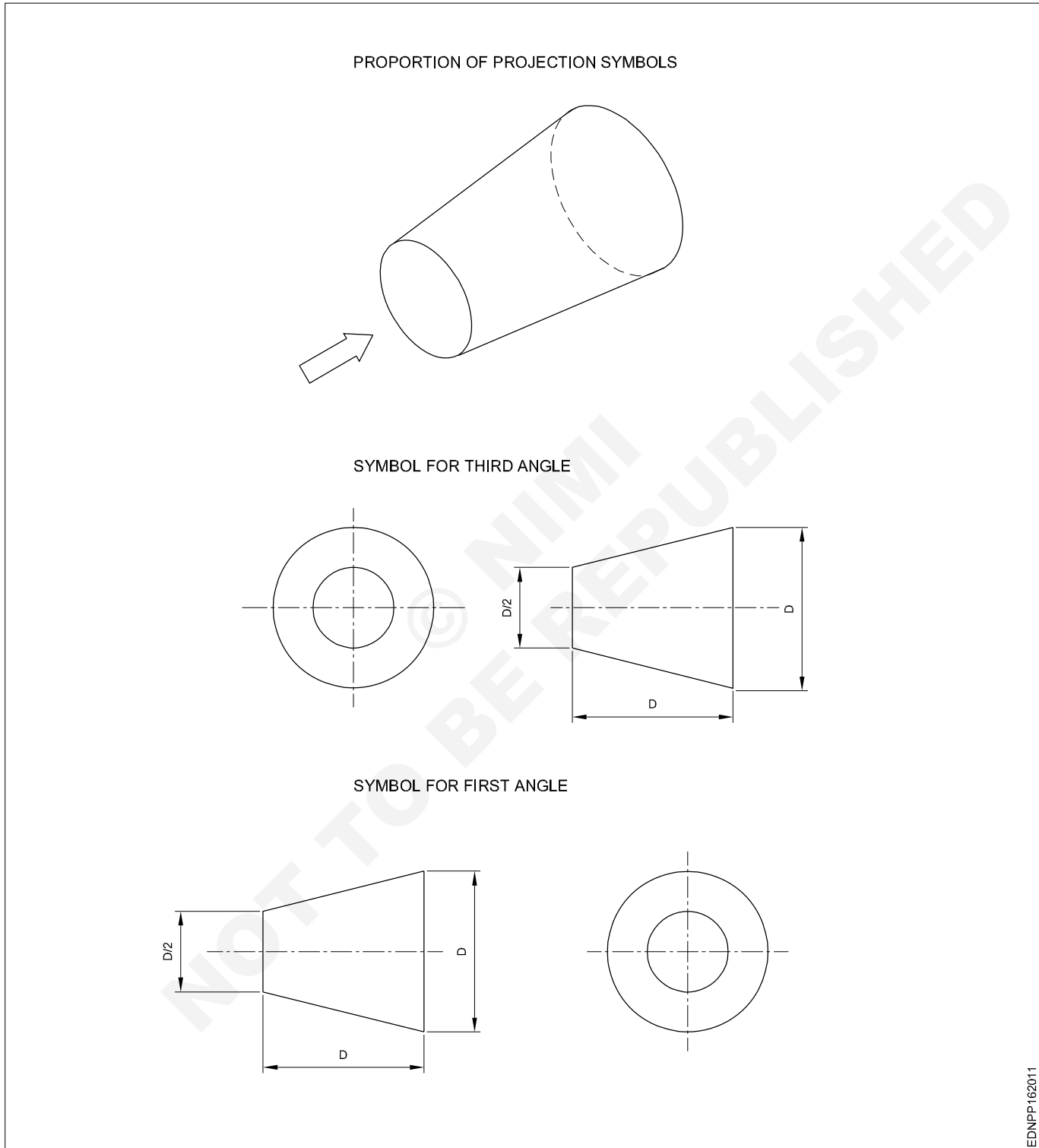

- 1 a Draw the symbol for 1st angle projection as per IS specification, if bigger dia D is 50 mm.
- b Draw the symbol for 3rd angle projection as per IS specification, if bigger dia D is 40 mm.

- 2 a Draw the symbol for 1st angle projection as per IS specification, if smaller dia D/2 is 20 mm.
- b Draw the symbol for 3rd angle projection as per IS specification, if smaller dia D/2 is 15 mm.

Method of 1st angle and 3rd angle projections

1st Angle projection (Fig 1)

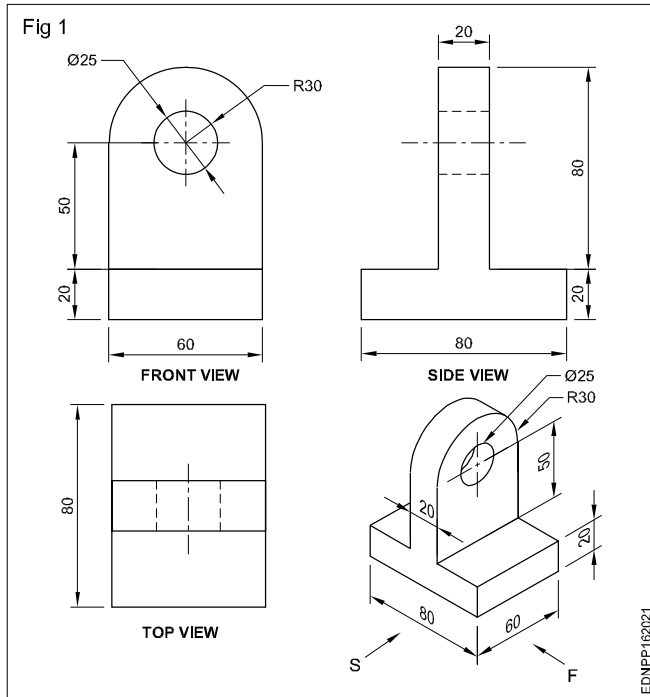

3rd Angle projection (Fig 2)

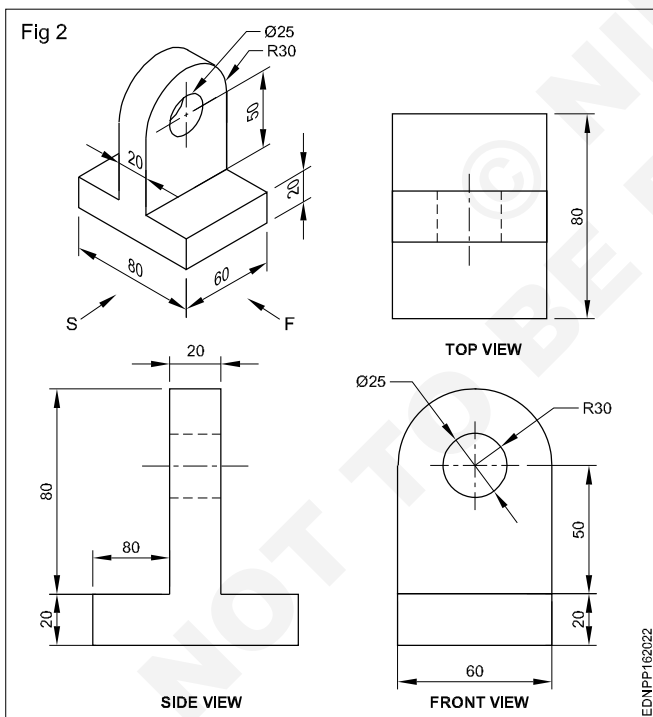

The two views thus required are to be obtained on two different planes which are mutually perpendicular (one HP and one VP) with the object remaining in the same position. The projection or the view obtained on the horizontal plane is called the top view or plan and the view obtained on the vertical plane is called elevation.

The placement of the front and top views when the horizontal plane is unfolded will be different in these two systems. It may be observed in Fig 3, that the first angle projection plan (top views) will be directly below the front view (Fig 4), whereas in 3rd angle projection top view lies directly above the elevation. (Fig 5)

Views can be drawn in any one of these two methods. However Indian Standard (BIS) has recommended the first angle method to be used in our country.

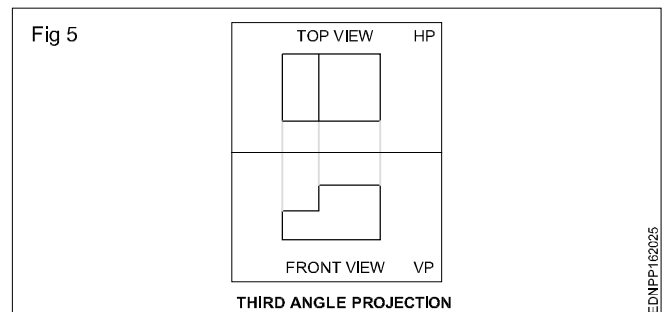
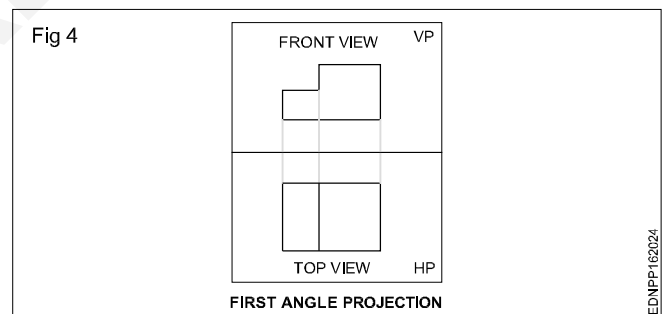
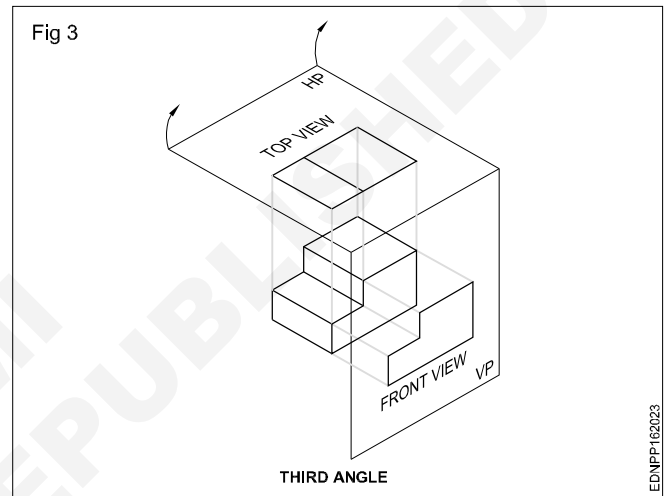

Principle of Orthographic Projection

ORTHO means Right angle: **GRAPHIC** means Drawing : ORTHOGRAPHIC means Right angled Drawing.

When the projectors are perpendicular to the plane on which the projection is obtained and are also parallel to each other, it is known as Orthographic Projection. The orthographic views should represent the true size and true shape of an object (as much as possible)

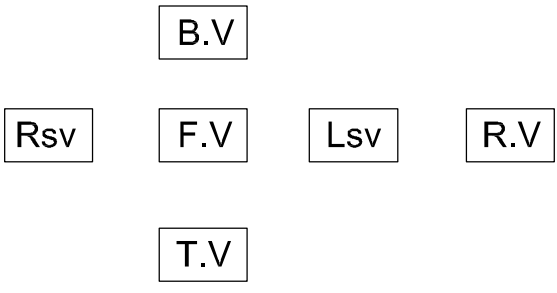
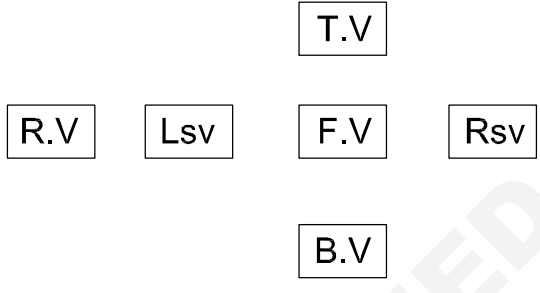
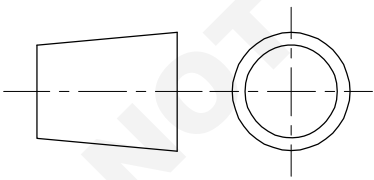
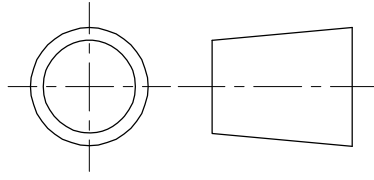
1 st Angle Method	3 rd Angle Method
<div style="text-align: center;">  </div> <p> F.V = Elevation T.V = Plan Lsv = Left side End view Rsv = Right side End view B.V = Bottom view R.V = Rear View </p>	<div style="text-align: center;">  </div> <p> Front view Top view Left side view Right side view Bottom View Rear View </p>
<p>Note : You have to decide to draw either in 1st angle or in 3rd angle projection</p> <ol style="list-style-type: none"> 1 Construct the scale (i.e. full scale, reduced / enlarged scale) to fit paper. 2 How many views to draw (minimum 3 views Front ,top, side). 	
<ol style="list-style-type: none"> 1 Object lies between observer and the planes of projections. 2 Object is situated on or above HP In front of VP.(1st quadrant) 3 Front view comes above top view. 4 Projection / Symbol <div style="text-align: center;">  </div> <p>5 European countries - ISO standard</p>	<ol style="list-style-type: none"> 1 Planes of projection lie between the object and the observer . 2 Object is situated below HP (i.e. on or above the ground)and behind VP.(3rd quadrant) 3 Top view comes above front view. 4 Projection / Symbol <div style="text-align: center;">  </div> <p>5 Canada, USA, Japan, Thailand</p>

Reading of job drawing related to plastic processing operator trade

Read and write the following. (Fig 1)

- 1 Write the name of mould as shown in Fig?
- 2 What is the difference between those two mould?
- 3 Write about hot runner mould.
- 4 Write about cold runner mould.

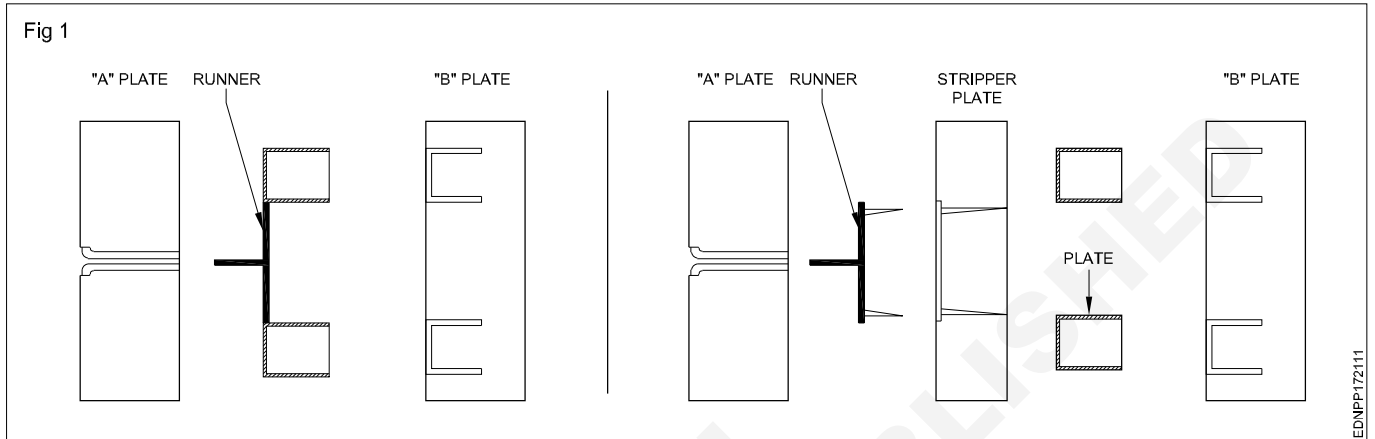

Read and write the following. (Fig 2)

- 1 Write the purpose of locating ring.
- 2 Write the function of sprue bush.
- 3 Write the function of guide pin.
- 4 What is the meaning of support plate?
- 5 Write the use of ejector pin.
- 6 Write the function of ejector return pin.
- 7 Write about retainer plate.

Read and write the following. (Fig 3&4)

- 1 What is the use of cold slug well.
- 2 Write about main runner and branch runner.
- 3 Write about gate.

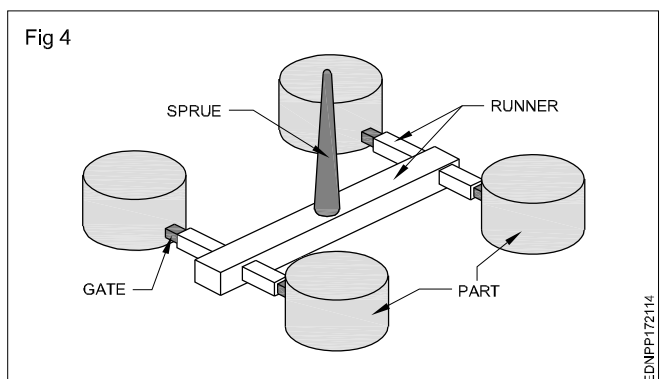
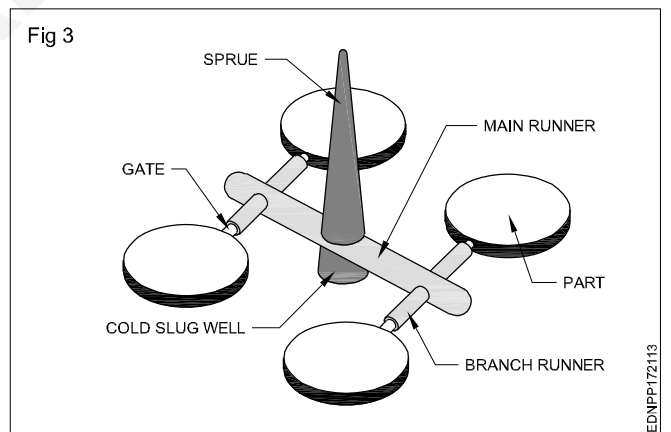
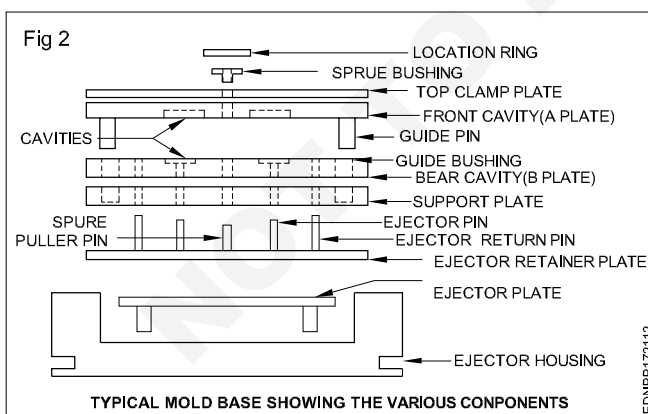

Read and write the following. (Fig 5)

- 1 Write the name of plate of support core.
- 2 Write the purpose of the ejector retainer.
- 3 Write the uses of guide pillar and guide bush.

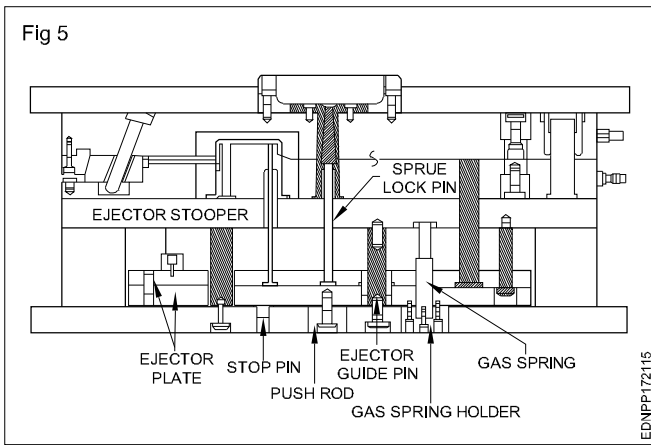

Typical screw nomenclature (Fig 6)

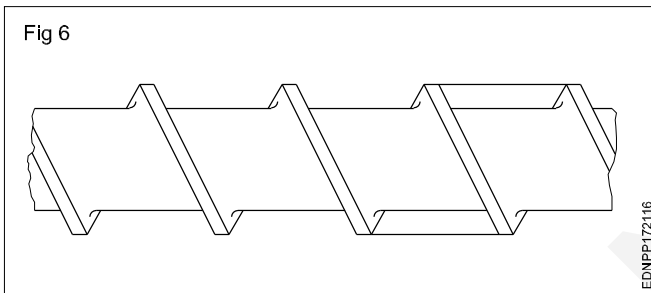

Read and write the following.

Identify and mark the following parts.

- Pitch
- Screw diameter
- Channel width
- Channel depth
- land width
- Root diameter
- Helix angle
- Screw leading edge
- Screw trailing edge

Read and write the following. (Fig 7)

- 1 Why different types of screw is required?
- 2 Which material made by plastic coted screw?
- 3 How plastic cating screw is produced from heat and corrosion?
- 4 How many sections are there in the screw?
- 5 Why screw provided different section?

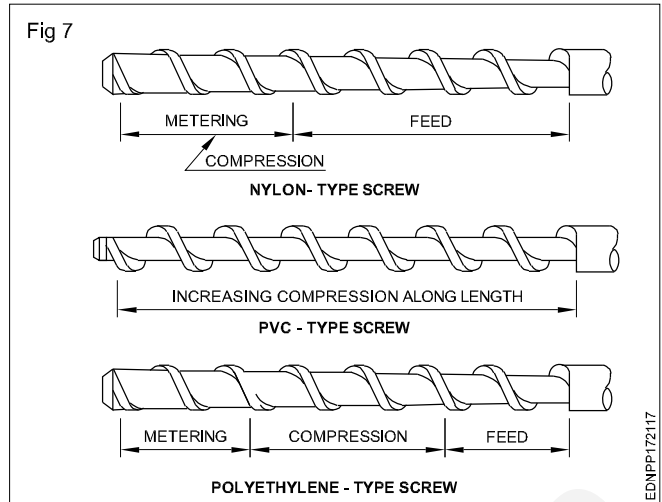

Read and write the following. (Fig 8)

- 1 Write the procedure of cleaning, oil and lubrication using in the barrel and screw.

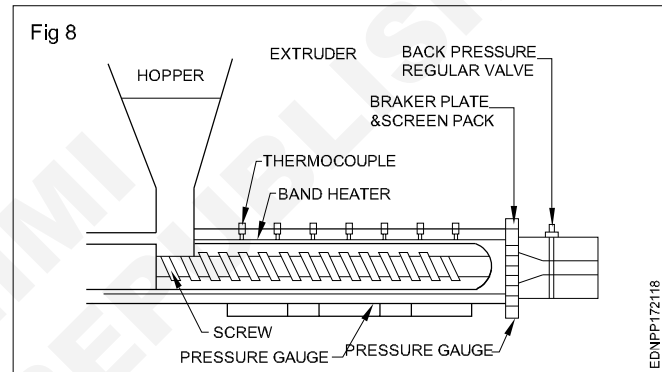

Read and write the following. (Fig 9)

- 1 How many clamping designs are there and write the name in moulding machine?
- 2 Write the procedure of each clamping designs.
- 3 Which clamping design is best.

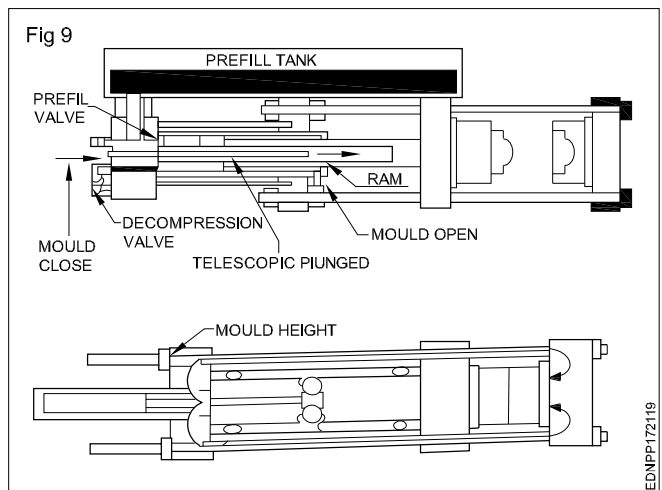

Read and write the following. (Fig 10)

- 1 What is the function of tie bar?
- 2 Write the name of heater?
- 3 Why different headers are provided?
- 4 How plastic material is injected to the mould?
- 5 Where to fix cavity plate?

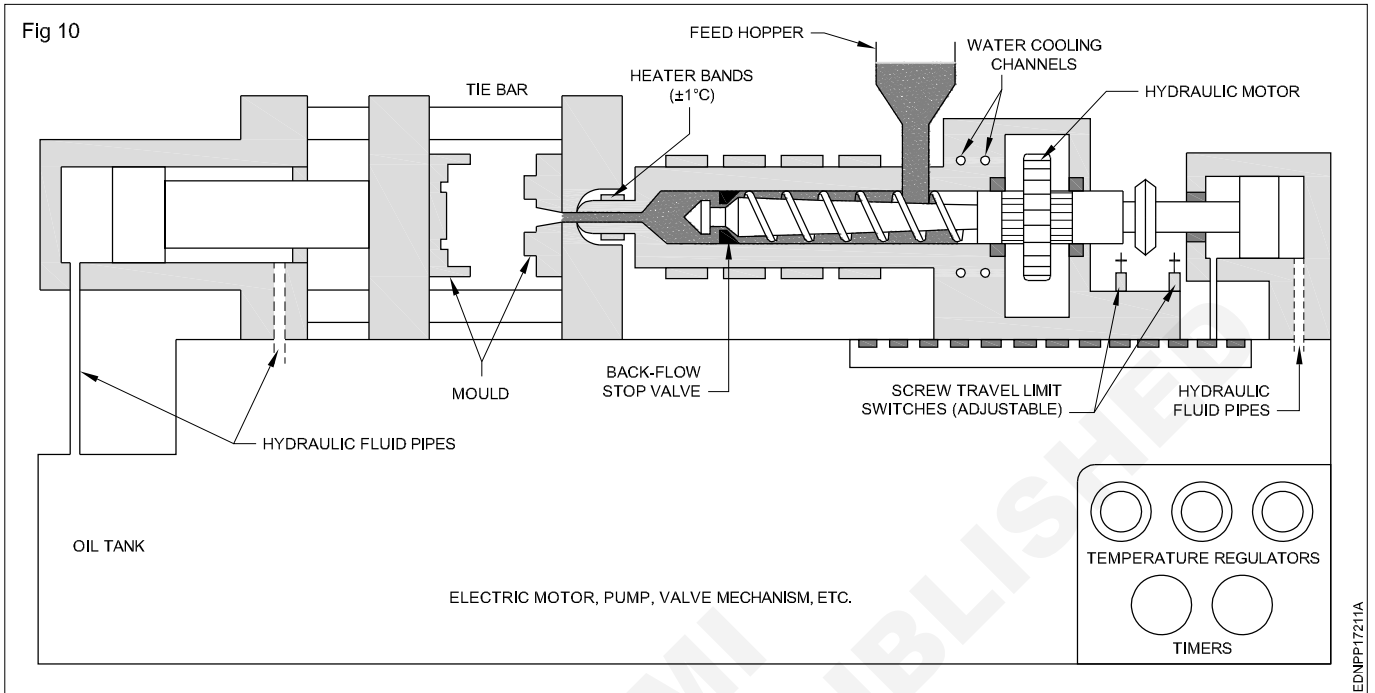

Read and write the following. (Fig 11)

- 1 Write the name of part from part number.

